

80751-E

(47- 800Hz)

LOW PROFILE

PFC BOOST CONVERTER MODULE



The **80751-E** PFC boost converter module is an enhanced version of the 80751 PFC boost converter module offering improvements in performance and safety. It is form, fit and functionally equivalent to the baseline 80751 module while adding internal protection against over-temperature and over-voltage fault conditions. Additionally, 2nd harmonic input current distortion amplitude has been significantly reduced for applications that require tying input neutral to the module's chassis pin (baseplate).

The **80751-E** module contains all of the necessary circuitry for complete power line compliance with aeronautics specification RTCA/DO-160E and Boeing's D6-36440 (C)*. Constructed using thermal circuit board technology and planar magnetics, these low profile (0.5" height) modules are both compact and rugged. Providing line rectification, minimized input current harmonic distortion, active inrush current limiting and near unity power factor; the **80751-E** is ideal for avionics' applications where power demands are in the 20W-75W range.

The **80751-E** provides a standard 350Vdc output, compatible with a broad range of off-the-shelf DC/DC converter modules. Utilizing a modular approach, system power supplies are easily configured with a few individual components required. Tedious design and development cycles normally associated with custom power solutions are no longer necessary with this approach.



FEATURES

	EXCEEDS BOEING SPECIFICATION D6-44588 (AA) FOR POWER FACTOR AND INPUT CURRENT HARMONIC DISTORTION LEVELS @ 400Hz ± 10% AND MEETS THE REQUIREMENTS OF RTCA/DO-160E FOR SINGLE PHASE, CATEGORY A(WF), INPUT FREQ: 360 – 800Hz
	EFFICIENCY: 87% TYPICAL
	WIDE INPUT RANGE: 97 - 134Vrms, 47 - 800Hz
	STANDARD 350Vdc OUTPUT COMPATIBLE WITH BROAD RANGE OF OFF-THE-SHELF DC/DC CONVERTER MODULES
	COMPLIES WITH RTCA/DO-160D EMI & SUSCEPTIBILITY (WITH EXTERNAL COMMON-MODE FILTER)
	VL94V-0 FLAMMABILITY CLASSIFICATION
	RUGGEDIZED SILICON-BASED ENCAPSULATED CONSTRUCTION WITH THERMAL CLAD TECHNOLOGY
	SIZE: 3.5" x 2.5" x 0.5", WEIGHT: 6oz.
	ACTIVE INRUSH CURRENT LIMITING
	OVERVOLTAGE AND THERMAL PROTECTION
	MTBF (RIAC 217Plus, Aic, 50°C OPERATING TEMPERATURE, 65% DC, 2190 Cycles/ yr.) 1.68 MILLION HOURS

* Requires external common-mode filter and hold up capacitors. See application notes for more information.

80751-E

(47- 800Hz)

LOW PROFILE

PFC BOOST CONVERTER MODULE



PERFORMANCE SUMMARY

PARAMETER	SPECIFICATIONS
OUTPUT POWER RANGE (1,2)	37.5 - 75W
OUTPUT VOLTAGE (3)	350Vdc
EFFICIENCY (4)	87%
SWITCHING FREQUENCY	100kHz
MINIMUM OUTPUT CAPACITANCE (5)	100uF
INPUT LINE TO NEUTRAL CAPACITANCE (6)	0.057uF
TOTAL LINE/NEUTRAL TO CHASSIS CAPACITANCE (6)	4700pF
ISOLATION VOLTAGE, INPUT/ OUTPUT TO CHASSIS (7)	1500Vac
MTBF (Aic, 30°C case)	1.68 Million Hours

NOTES:

1. Output power range in which module complies with RTCA/DO-160E, Category A(WF).
2. Module is power limited at upper output limit (Pmax).
3. DC output voltage $\pm 3\%$ when operating from no load through 75Wout (Pmax).
4. Minimum efficiency at Pmax. Efficiency is 89% typical.
5. Minimum output capacitance for proper boost module operation. Typical values will be larger to meet hold-up time requirements. Use polarized aluminum electrolytic type.
6. Capacitance tolerances are $\pm 20\%$.
7. 1500Vac, 60Hz for 60 seconds without arc or damage; 3.5mA maximum leakage current (internal line-to-earth capacitors installed)

TEMPERATURE CHARACTERISTICS

*AIRFLOW (LFM)	THERMAL IMPEDANCE (0s-a) (°C/W)
0 LFM	5.50
250 LFM	1.50
500 LFM	0.90

* Air velocity measured using a digital anemometer positioned within an airflow duct 4" X 3" above top of module

80751-E

(47- 800Hz)

LOW PROFILE

PFC BOOST CONVERTER MODULE



BLOCK DIAGRAM

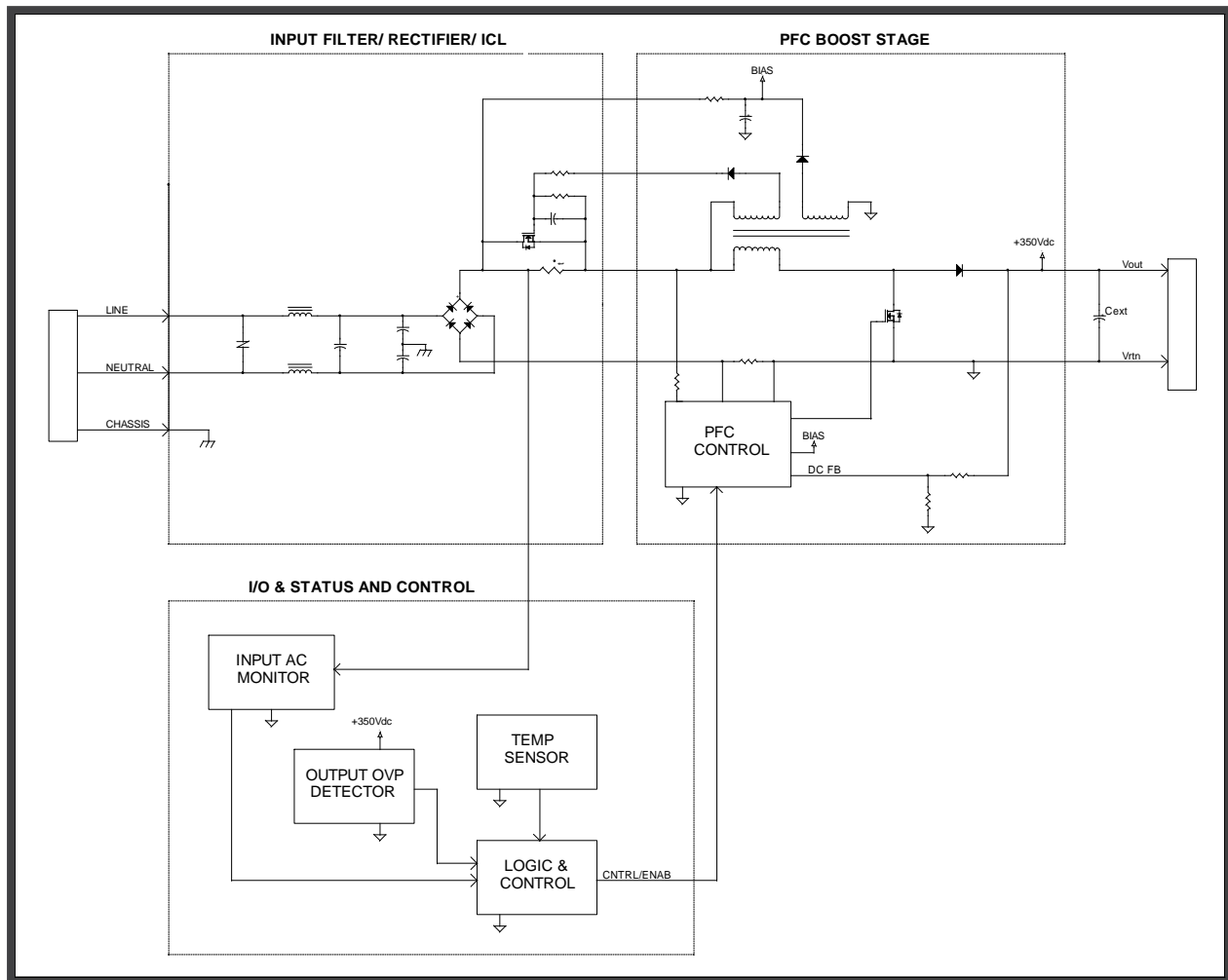

80751-E

(47- 800Hz)

LOW PROFILE

PFC BOOST CONVERTER MODULE



MECHANICAL DIAGRAM

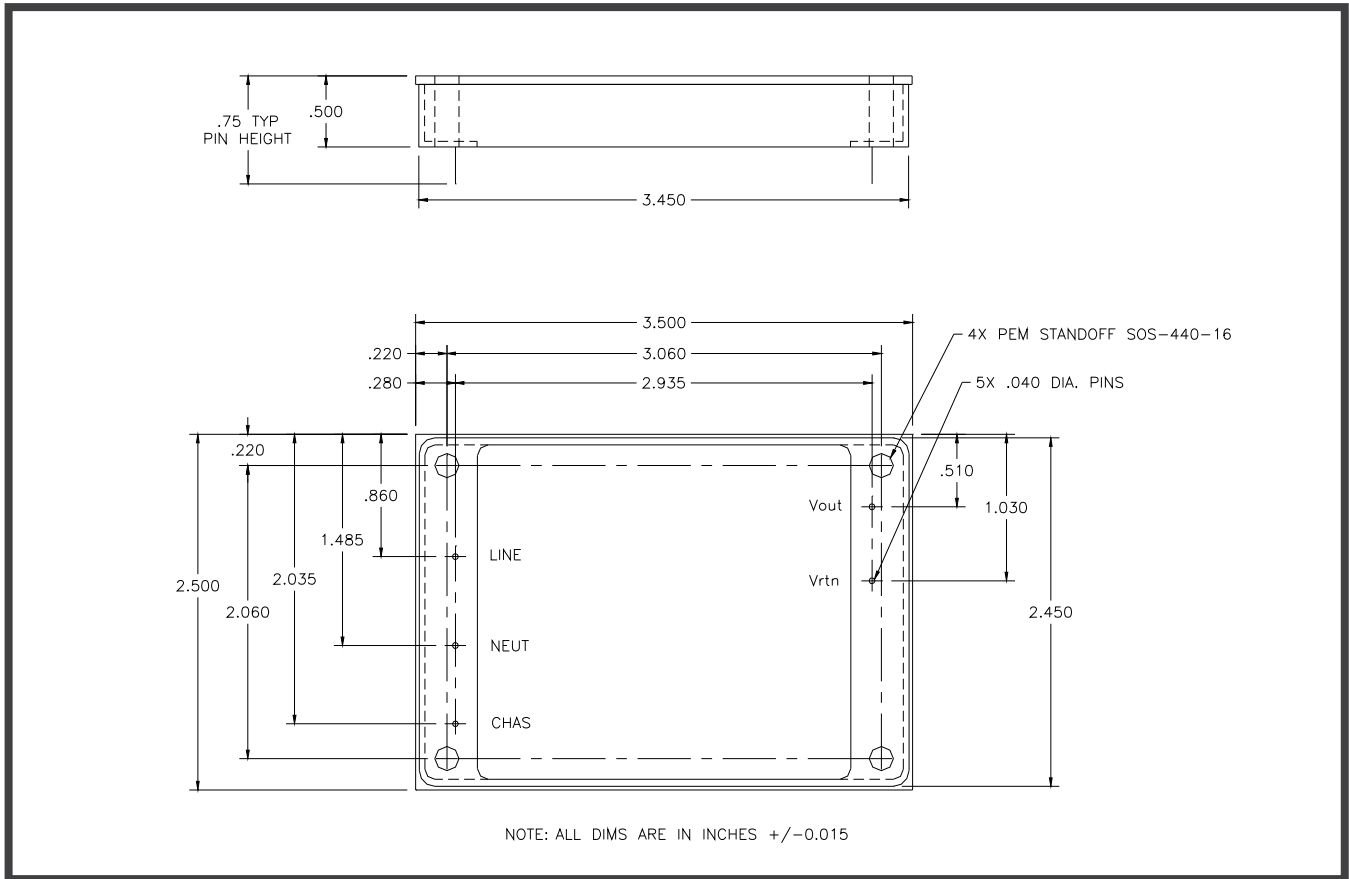

A DETAILED OUTLINE DRAWING CAN BE FURNISHED UPON REQUEST.

80751-E

(47- 800Hz)

LOW PROFILE

PFC BOOST CONVERTER MODULE



ELECTRICAL SPECIFICATIONS

UNLESS OTHERWISE SPECIFIED THE FOLLOWING TEST CONDITIONS APPLY: $T_A=25^{\circ}\text{C}$. CONSTANT ACTIVE LOAD APPLIED TO OUTPUT IN PARALLEL WITH 470uF CAPACITOR. $V_{IN}=115\text{Vrms}$, 400Hz, < 1% THD SINUSOID.

INPUT CHARACTERISTICS

PARAMETER	80751-E	REMARKS	NOTES
INPUT VOLTAGE RANGE	97 - 134Vrms	COMPLIES WITH NORMAL/ABNORMAL INPUT VOLTAGES PER RTCA/DO-160E, SECTION 16	2
INPUT FREQUENCY RANGE	47 - 800Hz	COMPLIES WITH DO-160E, SECTION 16, FOR A(WF) EQUIPMENT. OPERATES AT 47 - 360Hz WITH REDUCED DISTORTION PERFORMANCE	2
CONTINUOUS OUTPUT POWER	75W	OBSERVE MAXIMUM BASEPLATE TEMPERATURE	2
LEAKAGE CURRENT	< 5mA _{rms}	AC LINE/NEUTRAL TO CHASSIS, V_{in} @ 115Vrms, 400Hz	1
INRUSH CURRENT	< 5A _{pk}	COLD START, $V_{out} = 0\text{Vdc}$	2
TOTAL HARMONIC DISTORTION (INPUT CURRENT)	< 5%	$P_{out} \geq 37.5\text{W}$	2
INDIVIDUAL HARMONICS - AC CLEAN	EVEN: < 1% I_f / n , (n < 10) EVEN: < 0.1% I_f , (n ≥ 10) ODD: < 30% I_f / n ODD TRIPLENS: < 15% I_f / n	$V_{in} = 115\text{Vrms}$, 360 - 800Hz $V_{thd} \leq 1\%$ n = ORDER OF HARMONIC, 1 THRU 40; I_f = FUND CURRENT $P_{out} \geq 37.5\text{W}$ and INDIVIDUAL HARMONICS > 5mA _{rms}	1
INDIVIDUAL HARMONICS - DISTORTED INPUT	EVEN: < 1% $I_f / n + V_n$ (n < 10) EVEN: < 0.1% $I_f + V_n$ (n ≥ 10) ODD: < 30% $I_f / n + V_n$ ODD TRIPLENS: < 15% $I_f / n + V_n$	$V_{in} = 115\text{Vrms}$, 360 - 800Hz $V_{thd} \geq 5\%$, V_n = CORRESPONDING INPUT VOLTAGE HARMONIC n = ORDER OF HARMONIC, 1 THRU 40; I_f = FUND CURRENT $P_{out} \geq 37.5\text{W}$ and INDIVIDUAL HARMONICS > 5mA _{rms}	1
POWER FACTOR	0.90 min	$P_{out} > 25\text{W}$	2
CREST FACTOR (CURRENT)	1.314 - 1.514	RATIO OF PEAK/RMS	1
START-UP TIME	< 500mSec	$V_{out} > 200\text{Vdc}$	2
CONDUCTED EMISSIONS	RTCA/DO-160E CATEGORY M	REQUIRES EXTERNAL COMMON-MODE FILTER, SEE APPLICATION NOTES	1
AUDIO FREQUENCY CONDUCTED EMISSIONS	D6-16050-4 INDUCTIVE COUPLING PER SECTION 8.3.2	INPUT POWER LINES	1
OPERATING TEMPERATURE RANGE	-25°C TO 100°C	BASEPLATE	1
STORAGE TEMPERATURE RANGE	-55°C TO 100°C	NON-OPERATIONAL	1
OVERTEMPERATURE PROTECTION	100°C ± 5°C	BOOST INHIBITED WHEN OVERTEMPERATURE FAULT IS DETECTED. DURING INHIBIT, MODULE OUTPUT OPERATES AT $\sqrt{2} * V_{in}(\text{rms})$. AUTO RESET WITH ~ 15°C HYSTERESIS	1

Notes:

1. Ensured by design, not 100% tested in production.
2. 100% tested for specification compliance in production.

80751-E

(47- 800Hz)

LOW PROFILE

PFC BOOST CONVERTER MODULE



OUTPUT CHARACTERISTICS

PARAMETER	80751-E	REMARKS	NOTES
RATED OUTPUT VOLTAGE	350Vdc+/-3%	$0W \leq P_{out} \leq 75W$	2
MINIMUM OUTPUT CURRENT	0A _{dc}		2
MAXIMUM BASEPLATE TEMPERATURE	100°C		1
TEMPERATURE STABILITY COEF.	0.02% / °C	OUTPUT VOLTAGE	1
OUTPUT RIPPLE + NOISE (pk - pk)	< 0.5%	20MHz BANDWIDTH, $C_{out} = 470\mu F$	1
LINE REGULATION	< 1%	OUTPUT DEVIATION FOR $\pm 20\%$, STEP CHANGE IN LINE VOLTAGE	1
HOLD-UP TIME	0mSec	REQUIRES EXTERNAL HOLD-UP CAPACITOR, SEE APPLICATION NOTES	1
MINIMUM OUTPUT CAPACITANCE	100 μF	OBSERVE RIPPLE CURRENT REQUIREMENTS @ 800Hz & 100kHz FOR EXTERNAL OUTPUT CAPACITORS	1
MAXIMUM OUTPUT CAPACITANCE	1,000 μF	SPECIFIED IN ORDER NOT TO OVERSTRESS THE INTERNAL ACTIVE INRUSH CURRENT LIMITING CIRCUIT	1
ISOLATION VOLTAGE: INPUT TO OUTPUT	NONE	NON-ISOLATED DEVICE, ISOLATION VOLTAGE IS ACHIEVED IN DC/DC CONVERTERS	1
ISOLATION VOLTAGE: INPUT/OUTPUT TO CHASSIS	1500Vac / 60Hz	NO ARCING OR DAMAGE FOR 60 SECOND DURATION 3.5mA _{rms} MAX LEAKAGE CURRENT	2
SHORT-CIRCUIT PROTECTION	NONE	FUSE INPUT WITH 2A FAST BLOW FUSE	1
OVERVOLTAGE PROTECTION	OVP SET-POINT: 405V \pm 2%	OUTPUT VOLTAGE LIMITED, AUTO RECOVERY	1

Notes:

1. Ensured by design, not 100% tested in production.
2. 100% tested for specification compliance in production.