

81357-X-MPM

PFC BOOST CONVERTER MODULE (47—800Hz)



The **81357-X-MPM** PFC boost converter module contains all the necessary circuitry for complete power line compliance with aeronautics specification RTCA/DO-160E and Boeing's D6-36440(C). Housed in an all aluminum enclosure, with silicon-based encapsulant, the **81357-X-MPM** module is compact and rugged. Providing line rectification, minimized input current harmonic distortion, active inrush current limiting and near unity power factor; the **81357-X-MPM** is ideal for avionics applications where power demands are in the 60W-120W range.

The **81357-X-MPM** provides a standard 350Vdc output, compatible with a broad range of off-the-shelf DC/DC converter modules. Utilizing a modular approach, system power supplies are easily configured with a few individual components required. Tedious design and development cycles normally associated with custom power solutions are no longer necessary with this approach. Reliable, compliant power supplies can be configured in weeks, not months, without the need for specialized Power Supply Engineers.



FEATURES

	EXCEEDS BOEING'S RTCA/DO-160E, CATEGORY A(WF) FOR INPUT CURRENT HARMONIC DISTORTION LEVELS @ 360-800Hz
	EFFICIENCY: 89% TYPICAL
	WIDE OPERATING INPUT RANGE: 90 - 134Vrms, 360Hz - 800Hz (See input characteristics table for details)
	STANDARD 350Vdc OUTPUT COMPATIBLE WITH BROAD RANGE OF OFF-THE-SHELF DC/DC CONVERTER MODULES
	COMPLIES WITH RTCA/DO-160E, CATEGORY M, EMISSIONS & SUSCEPTIBILITY
	VL94V-0 FLAMMABILITY CLASSIFICATION
	RUGGEDIZED SILICON-BASED ENCAPSULATED CONSTRUCTION WITH INTEGRAL HEATSINK OR FLAT TOP
	SIZE: FINNED VERSION: 4.0" x 2.3" x 1.25", WEIGHT = 15oz, FLAT TOP VERSION: 4.0" x 2.3" x 0.99", WEIGHT = 14oz
	ACTIVE INRUSH CURRENT LIMITING
	MTBF (RIAC 217Plus, Aic, 50°C OPERATING TEMPERATURE, 65% DC, 2190 Cycles/ yr.) 1.39 MILLION HOURS

81357-X-MPM

PFC BOOST CONVERTER MODULE (47—800Hz)



OVERVIEW

PARAMETER	81357-X-MPM
OUTPUT POWER RANGE (1,2)	60-120W
OUTPUT VOLTAGE (3)	350Vdc
EFFICIENCY (4)	87%
SWITCHING FREQUENCY	100kHz
MINIMUM OUTPUT CAPACITANCE (5)	100uF
INPUT LINE TO NEUTRAL CAPACITANCE (6)	0.15uF
TOTAL LINE/NEUTRAL TO CHASSIS CAPACITANCE (6)	8600pF

NOTES:

1. Output power range in which module complies with RTCA/DO-160E, Category A(WF).
2. Module is power limited at upper output limit, (Pmax).
3. DC output voltage $\pm 3\%$ when operating within 20-120W output power range. The DC output voltage tolerance is $\pm 5\%$ when operating at no load through 20W output power.
4. Minimum efficiency at Pmax.
5. Minimum output capacitance for proper boost module operation. Typical values will be larger to meet hold-up time requirements. Use polarized aluminum electrolytic type.
6. Capacitance tolerances are $\pm 20\%$.

TEMPERATURE CHARACTERISTICS

*AIRFLOW (LFM)	THERMAL IMPEDANCE (θ_{s-a}) ($^{\circ}\text{C}/\text{W}$)	
	INTEGRAL FINS	FLAT TOP (W/O FINS)
Air velocity through cross-sectional area of fins or across flat top		
0 LFM	3.27	4.34
250 LFM	1.06	2.28
500 LFM	0.59	1.59
750 LFM	0.35	1.07

* Air velocity measured using a digital anemometer positioned within an airflow duct 4" X 3" above top of module

81357-X-MPM

PFC BOOST CONVERTER MODULE (47—800Hz)



ELECTRICAL SPECIFICATIONS

UNLESS OTHERWISE SPECIFIED THE FOLLOWING TEST CONDITIONS APPLY: $T_A=25^{\circ}\text{C}$. CONSTANT ACTIVE LOAD APPLIED TO OUTPUT IN PARALLEL WITH 470uF CAPACITOR. $V_{IN}=115\text{Vrms}$, 400Hz, < 1% THD SINUSOID.

INPUT CHARACTERISTICS

PARAMETER	81357-X-MPM	REMARKS	NOTES
INPUT VOLTAGE RANGE	90 - 134Vrms (360 - 800Hz) 104 - 134Vrms (47 - 360Hz)	COMPLIES WITH NORMAL/ ABNORMAL INPUT VOLTAGES PER RTCA/DO-160E, SECTION 16. MODULE MUST START OVER THE INPUT RANGE OF 96Vrms - 134Vrms (360-800Hz) AND REMAIN ENABLED DOWN TO 90Vrms AT FULL LOAD.	2
INPUT FREQUENCY RANGE	47 - 800Hz	COMPLIES WITH DO-160E, SECTION 16, FOR A(WF) EQUIPMENT. OPERATES AT 47 - 360Hz WITH REDUCED DISTORTION PERFORMANCE	2
CONTINUOUS OUTPUT POWER	120W	OBSERVE MAXIMUM BASEPLATE TEMPERATURE	2
LEAKAGE CURRENT	< 5mArms	AC LINE/NEUTRAL TO CHASSIS, V_{in} @ 115Vrms, 400Hz	1
BOOST INHIBIT	DISABLE PIN PULLED TO < 1V WITH RESPECT TO V_{rtn}	BOOST FUNCTION DISABLED. V_{out} WILL OPERATE AT $\sqrt{2} * V_{in}(\text{rms})$ DEPENDING ON OUTPUT LOADING	2
INRUSH CURRENT	< 3.3Apk typical < 6.0Apk maximum	COLD START; INITIAL $V_{out} = 0\text{Vdc}$	2
EFFICIENCY	87% minimum	115Vrms, 400Hz, FULL 120W LOAD, NO EXTERNAL FILTER	2
TOTAL HARMONIC DISTORTION	< 3.5% at 400Hz < 5.5% at 800Hz	$P_{out} \geq 60\text{W}$, INPUT CURRENT, WITH OR WITHOUT APP NOTE EXTERNAL FILTER	2
INDIVIDUAL HARMONICS - AC CLEAN	EVEN: < 1% I_f / n , ($n < 10$) EVEN: < 0.1% I_f ($n \geq 10$) ODD: < 30% I_f / n ODD TRIPLENS: < 15% I_f / n	$V_{in} = 115\text{Vrms}$, 360 - 800Hz $V_{thd} \leq 1\%$ $n = \text{ORDER OF HARMONIC, 1 THRU 40,}$ $I_f = \text{FUNDAMENTAL CURRENT}$ $60\text{W} \leq P_{out} \leq 120\text{W}$ and INDIVIDUAL HARMONICS > 5mArms WITH OR WITHOUT APP NOTE EXTERNAL FILTER	1
INDIVIDUAL HARMONICS - DISTORTED INPUT	EVEN: < 1% $I_f / n + V_n$ ($n < 10$) EVEN: < 0.1% $I_f + V_n$ ($n \geq 10$) ODD: < 30% $I_f / n + V_n$ ODD TRIPLENS: < 15% $I_f / n + V_n$	$V_{in} = 115\text{Vrms}$, 360 - 800Hz $V_{thd} \geq 10\%$, $V_n = \text{CORRESPONDING INPUT VOLTAGE HARMONIC}$ $n = \text{ORDER OF HARMONIC, 1 THRU 40,}$ $I_f = \text{FUNDAMENTAL CURRENT}$ $60\text{W} \leq P_{out} \leq 120\text{W}$ and INDIVIDUAL HARMONICS > 5mArms WITH OR WITHOUT APP NOTE EXTERNAL FILTER	1

81357-X-MPM

PFC BOOST CONVERTER MODULE (47—800Hz)



INPUT CHARACTERISTICS—CONTINUED

PARAMETER	81357-X-MPM	REMARKS	NOTES
POWER FACTOR	0.98 minimum	$P_{out} \geq 60W$, 360Hz – 800Hz, EXTERNAL APP NOTE FILTER OR EXTERNAL “X” CAPACITANCE LIMITED TO 0.068 μ F	2
CREST FACTOR	1.314 - 1.514	INPUT CURRENT, RATIO OF PEAK/RMS	1
START-UP TIME	< 1.25 seconds	$V_{out} > 200V_{dc}$	2
CONDUCTED EMISSIONS	RTCA/DO-160E	CATEGORY M	1
OPERATING TEMP RANGE	-40°C TO 100°C	BASEPLATE	1
STORAGE TEMP RANGE	-55°C TO 100°C	NON-OPERATING	1
OVERTEMPERATURE PROTECTION	100°C \pm 5°C	BOOST INHIBITED WHEN OVERTEMPERATURE FAULT IS DETECTED. DURING INHIBIT, MODULE OUTPUT OPERATES AT $\sqrt{2} * V_{in}(rms)$. AUTO RESET WITH $\sim 15^\circ C$ HYSTERESIS	1

Notes:

1. Ensured by design, not 100% tested in production.
2. 100% tested for specification compliance in production.

81357-X-MPM

PFC BOOST CONVERTER MODULE (47—800Hz)



OUTPUT CHARACTERISTICS

PARAMETER	81357-X-MPM	REMARKS	NOTES
RATED OUTPUT VOLTAGE	350Vdc \pm 3%, Pout \geq 20W 350Vdc \pm 5%, Pout < 20W		2
MINIMUM OUTPUT CURRENT	0Adc		2
MAXIMUM BASEPLATE TEMPERATURE	100°C		1
TEMPERATURE STABILITY COEF.	0.02% / °C	OUTPUT VOLTAGE	1
OUTPUT RIPPLE + NOISE (pk - pk)	< 0.5%	20MHz BANDWIDTH, Cout = 470uF	1
LINE REGULATION	< 1%	OUTPUT DEVIATION FOR \pm 20%, STEP CHANGE IN LINE VOLTAGE	1
HOLD-UP TIME	0mSec	REQUIRES EXTERNAL HOLD-UP CAPACITOR, SEE APPLICATION NOTES FOR DETAILS	1
MINIMUM OUTPUT CAPACITANCE	100uF	OBSERVE RIPPLE CURRENT REQUIREMENTS @ 800Hz & 100kHz FOR EXTERNAL OUTPUT CAPACITORS	1
MAXIMUM OUTPUT CAPACITANCE	1,200uF	SPECIFIED IN ORDER NOT TO OVERSTRESS THE INTERNAL ACTIVE INRUSH CURRENT LIMITING CIRCUIT	1
ISOLATION VOLTAGE: INPUT TO OUTPUT	NONE	NON-ISOLATED DEVICE. ISOLATION VOLTAGE IS ACHIEVED IN DC/DC CONVERTERS	--
ISOLATION VOLTAGE: INPUT/OUTPUT TO CHASSIS	1500Vrms	NO ARCING OR DAMAGE FOR 60 SECOND DURATION, 7mA MAXIMUM LEAKAGE CURRENT	2
SHORT-CIRCUIT PROTECTION	NONE	FUSE INPUT WITH 3A FAST BLOW FUSE	1
OVERVOLTAGE PROTECTION	OVP SET-POINT: 406V \pm 5%	OUTPUT VOLTAGE LIMITED, AUTO RECOVERY	1
20Vbias OUTPUT	17.8 \pm 1.2Vdc	REFERENCED TO Vrtn, MAXIMUM SOURCE CURRENT IS 5mA AT MODULE START-UP AND 12mA THEREAFTER UNLESS INCORPORATING START-UP ASSIST CIRCUIT (SEE APP NOTES). VOLTAGE MAY DROP BELOW 16.6V WHEN BOOST MODULE IS DISABLED OR LIGHTLY LOADED ON THE OUTPUT. 20Vbias OUTPUT IS INTERNALLY OVER-CURRENT PROTECTED.	2

Notes:

1. Ensured by design, not 100% tested in production.
2. 100% tested for specification compliance in production.

81357-X-MPM

PFC BOOST CONVERTER MODULE (47—800Hz)



APPLICATION NOTES

SEE 81357 SERIES MODULE APPLICATION NOTES (UNDER SUPPORT TAB) FOR A COMPLETE SET OF APPLICATION NOTES.

TYPICAL CIRCUIT WHEN INCORPORATING THE 81357-X-MPM MODULE:

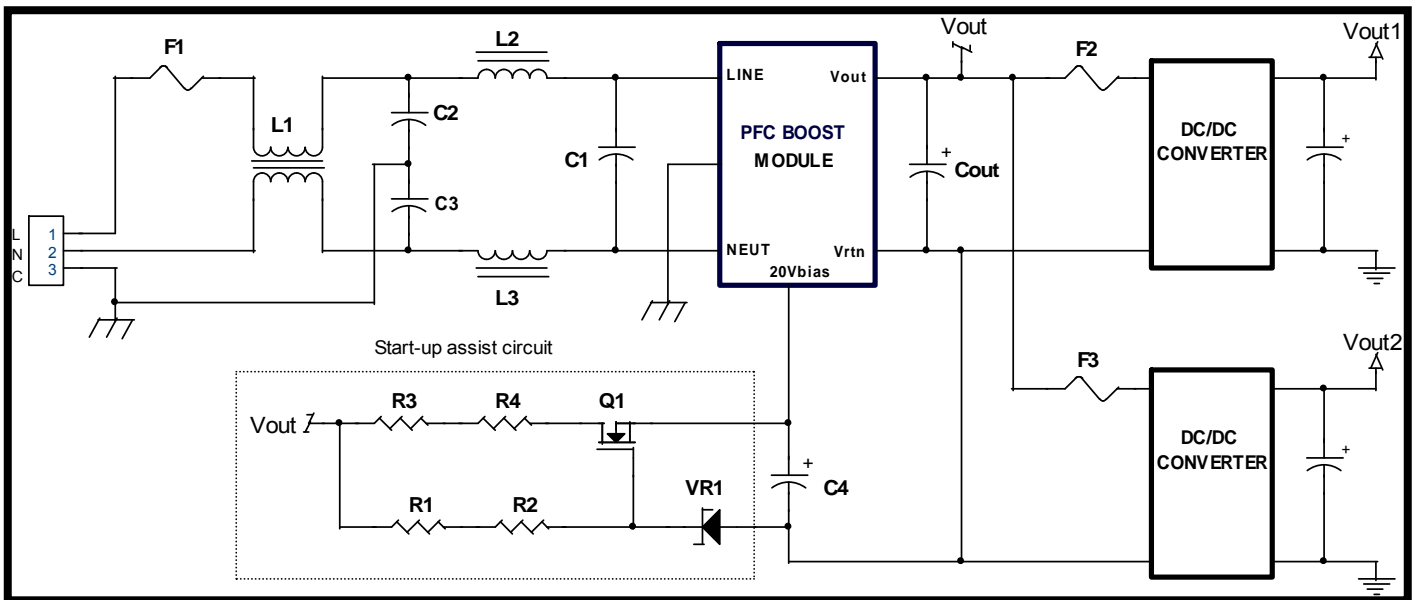

Designator	P/N or Description
F1	3A, 125Vac, Slow-Blow
F2, F3	2.5A, 450V, PC-Tron
L1	JW Miller #7109 or #7116
L2, L3	200uH, 1.7Apk rating
C1	0.033uF, 275Vac, "X2"
C2, C3	3300pF, 250Vac, "Y1/Y2"
C4	470uF, 25V, Alum
R1, R2	365k, 1/8W, 1206
R3, R4	12k, 3W, 5%, 250Vmin
Q1	IRFR420, 500V, DPAK
VR1	MMSZ5248BT1, 18V, 1/2W

81357-X-MPM

PFC BOOST CONVERTER MODULE (47—800Hz)



To inquire about price and delivery please contact PPI's sales department at:
info@ppipower.com

ORDERING INFORMATION

PPI PART NUMBER: **81357 -** **- MPM**

INSERT FOR FIN AND MOUNTING CONFIGURATION:	"H"	"F"	"H1"	"F1"
	INTEGRAL FIN, NON THREADED MOUNTING HOLES	FLAT TOP, NON THREADED MOUNTING HOLES *	INTEGRAL FIN, THREADED MOUNTING HOLES	FLAT TOP, THREADED MOUNTING HOLES

*** OPTIONAL CROSS HATCH HEATSINK AVAILABLE FOR "F" VERSION**