

82005-X-PBF

(47– 800Hz)

350V_{DC} / 200W OUTPUT

PFC Boost Converter Module



The **82005-X-PbF** PFC boost converter module contains all the necessary circuitry for complete power line compliance with aeronautics specification RTCA/DO-160F and Boeing's D6-36440 (C). Housed in an all aluminum enclosure and encapsulated with a silicon-based compound, the **82005-X-PbF** module is compact and rugged. Providing line rectification, minimized input current harmonic distortion, active inrush current limiting and near unity power factor; the **82005-X-PbF** is ideal for avionics applications where power demands are in the 100W-200W range.

The **82005-X-PbF** provides a standard 350Vdc output compatible with a broad range of off-the-shelf DC/DC converter modules. Utilizing a modular approach, system power supplies are easily configured with a few individual components required. Tedious design and development cycles normally associated with custom power solutions are no longer necessary with this approach. Reliable, compliant power supplies can be configured in weeks, not months, without the need for specialized Power Supply Engineers.



FEATURES

	EXCEEDS AERONAUTICS' SPECIFICATION RTCA/DO-160F FOR POWER FACTOR AND INPUT CURRENT HARMONIC DISTORTION LEVELS OVER THE WIDE FREQUENCY RANGE OF OPERATION (360 - 800Hz)
	EFFICIENCY: 89% TYPICAL
	COMPLIES WITH RTCA/DO-160F FOR CONDUCTED EMISSIONS, SUSCEPTIBILITY AND POWER INPUT (SECTION 16), SEE NOTE 7
	WIDE INPUT RANGE: 96 - 134V _{rms} , 47 - 800Hz
	STANDARD 350Vdc OUTPUT COMPATIBLE WITH BROAD RANGE OF <i>OFF-THE-SHELF</i> DC/DC CONVERTER MODULES
	COMPLIES WITH RTCA/DO-160F, CATEGORY M, EMI & SUSCEPTIBILITY
	VL94V-0 FLAMMABILITY CLASSIFICATION
	RUGGEDIZED SILICON-BASED ENCAPSULATED CONSTRUCTION WITH INTEGRAL HEATSINK
	SIZE: (FINNED) 4.06" x 2.36" x 1.25", WEIGHT = 15oz. (FLAT TOP) 4.06" x 2.36" x 0.99", WEIGHT = 13oz.
	ACTIVE INRUSH CURRENT LIMITING

82005-X-PBF

(47– 800Hz)

350V_{DC} / 200W OUTPUT

PFC Boost Converter Module



TEMPERATURE CHARACTERISTICS

*AIRFLOW (LFM)	THERMAL IMPEDANCE (Θ_{s-a}) (°C/W)	
	INTEGRAL FINS	FLAT TOP (W/OUT FINS)
Airflow applied through cross sectional area of fins or across flat-top		
0 LFM	3.3	4.4
250 LFM	1.1	2.3
500 LFM	0.6	1.6

* Air velocity measured using a digital anemometer positioned within an airflow duct 4" X 3" above top of module

OVERVIEW

PARAMETER	82005-X-PbF
OUTPUT POWER RANGE (1,2)	100-200W
OUTPUT VOLTAGE (3)	350Vdc
EFFICIENCY (4)	87%
SWITCHING FREQUENCY	125kHz
MINIMUM OUTPUT CAPACITANCE (5)	220uF
INPUT LINE TO NEUTRAL CAPACITANCE (6)	0.26uF
TOTAL LINE/NEUTRAL TO CHASSIS CAPACITANCE (6)	8600pF

Notes:

1. Output power range in which module complies with RTCA/DO-160F for harmonic distortion (A(WF)).
2. Module output power is limited to approximately 250W; exceeding this level will cause the output to foldback.
3. DC output voltage $\pm 3\%$ when operating within 20-200W output power range. The DC output voltage tolerance is $\pm 5\%$ when operating at no load through 20W output power.
4. Minimum efficiency at nominal line and maximum output power.
5. Minimum output capacitance for proper boost module operation. Typical values will be larger to meet hold-up time requirements. Use polarized aluminum electrolytic type.
6. Capacitance tolerances are $\pm 20\%$.
7. Requires external filter (differential and common mode) installed on power lines for full compliance when installed in upper level assembly, see application section for details.



82005-X-PBF

(47– 800Hz)

350V_{DC} / 200W OUTPUT

PFC Boost Converter Module



MECHANICAL DIAGRAM

① HEIGHT OF UNIT WHEN ORDERING FLAT TOP UNIT.

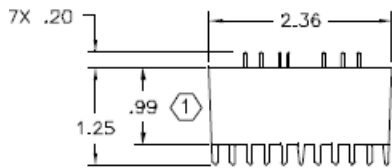
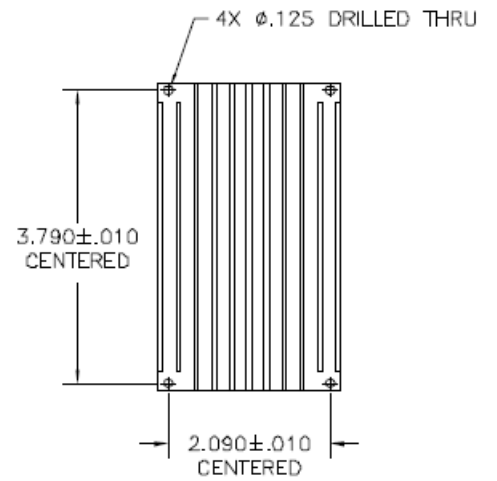
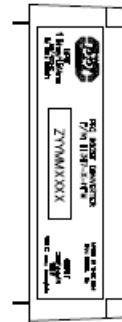
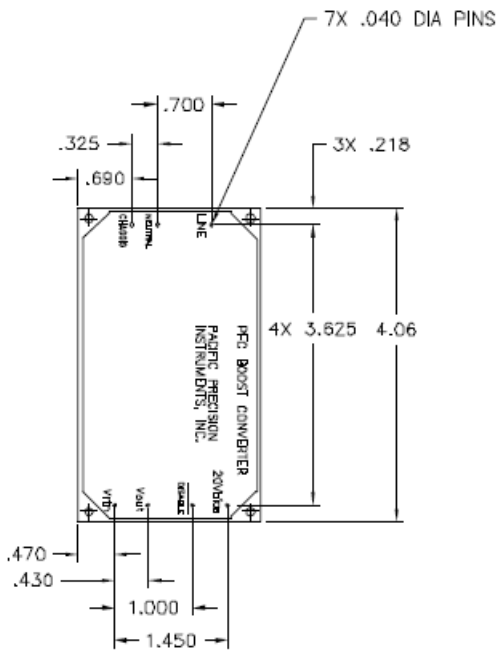

82005-X-PBF

(47– 800Hz)

350V_{DC} / 200W OUTPUT

PFC Boost Converter Module



ELECTRICAL SPECIFICATIONS

UNLESS OTHERWISE SPECIFIED THE FOLLOWING TEST CONDITIONS APPLY: T_A=25°C. CONSTANT ACTIVE LOAD APPLIED TO OUTPUT IN PARALLEL WITH 220uF CAPACITOR. VIN=115Vrms, 400Hz, < 1% THD SINUSOID.

INPUT CHARACTERISTICS

PARAMETER	82005-X-PbF	REMARKS	NOTES
INPUT VOLTAGE RANGE	96 - 134Vrms	COMPLIES WITH NORMAL/ABNORMAL INPUT VOLTAGES PER RTCA/DO-160F, SECTION 16.	2
INPUT FREQUENCY RANGE	47 - 800Hz	COMPLIES WITH DO-160F, SECTION 16, FOR A(WF) EQUIPMENT. OPERATES AT 47 - 360Hz WITH REDUCED DISTORTION PERFORMANCE.	2
CONTINUOUS OUTPUT POWER	200W	OBSERVE MAXIMUM BASEPLATE TEMPERATURE.	2
LEAKAGE CURRENT	< 5mA _{rms}	AC LINE/NEUTRAL TO CHASSIS, V _{in} @ 115Vrms, 400Hz	1
INRUSH CURRENT	< 7.5A _{pk}	COLD START, V _{out} = 0Vdc	2
TOTAL HARMONIC DISTORTION (INPUT CURRENT)	< 5%	P _{out} > 100W	2
INDIVIDUAL HARMONICS - AC CLEAN	EVEN: < 1% I _f / n, (n ≤ 4) EVEN: < 0.25% I _f (n ≥ 6) ODD: < 30% I _f / n ODD TRIPLES: < 15% I _f / n	WITH EXTERNAL FILTER PER APP NOTE V _{in} = 115Vrms, 360 - 800Hz V _{thd} ≤ 1.25% n = ORDER OF HARMONIC, 1 THRU 40, I _f = FUNDAMENTAL CURRENT FOR ALL P _{out} ≥ 100W and INDIVIDUAL HARMONICS > 10mA _{rms}	1
INDIVIDUAL HARMONICS - DISTORTED INPUT	EVEN: < 1% I _f / n + V _n (n ≤ 4) EVEN: < 0.25% I _f + V _n (n ≥ 6) ODD: < 30% I _f / n + V _n ODD TRIPLES: < 15% I _f / n + V _n	WITH EXTERNAL FILTER PER APP NOTE V _{in} = 115Vrms, 360 - 800Hz V _{thd} ≥ 10%, V _n = CORRESPONDING INPUT VOLTAGE HARMONIC n = ORDER OF HARMONIC, 1 THRU 40, I _f = FUNDAMENTAL CURRENT FOR ALL P _{out} ≥ 100W and INDIVIDUAL HARMONICS > 10mA _{rms}	1
POWER FACTOR	0.98 min	WITH EXTERNAL FILTER PER APP NOTE P _{out} ≥ 100W	2
CREST FACTOR (CURRENT)	1.314 - 1.514	RATIO OF PEAK/RMS.	1
START-UP TIME	< 1.25Sec	V _{out} > 200Vdc.	2
CONDUCTED EMISSIONS	RTCA/DO-160E	CATEGORY M, IMPLEMENTATION OF SMALL EXTERNAL LINE FILTER MAY BE NECESSARY. SEE APPLICATION NOTES FOR DETAILS.	1
OPERATING TEMPERATURE RANGE	-40°C TO 100°C	BASEPLATE.	1
STORAGE TEMPERATURE RANGE	-55°C TO 100°C	NON-OPERATING.	1
OVERTEMPERATURE PROTECTION	100°C +15°C, -10°C	BOOST INHIBITED WHEN OVERTEMPERATURE FAULT IS DETECTED. DURING INHIBIT, MODULE OUTPUT OPERATES AT √2*V _{in} (rms). AU-TO RESET WITH ~ 15°C HYSTERESIS	1
BOOST INHIBIT	DISABLE PIN PULLED TO <1V WITH RESPECT TO V _{rtn}	BOOST FUNCTION DISABLED. DURING INHIBIT, MODULE OUTPUT OPERATES AT V _{in} (rms) * √2.	2



82005-X-PBF

(47– 800Hz)

350V_{DC} / 200W OUTPUT

PFC Boost Converter Module



OUTPUT CHARACTERISTICS

PARAMETER	82005-X-PbF	REMARKS	NOTES
RATED OUTPUT VOLTAGE	350Vdc \pm 3%, Pout \geq 20W 350Vdc \pm 5%, Pout < 20W		2
MINIMUM OUTPUT CURRENT	0A _{dc}		2
QUIESCENT POWER	2W	TYPICAL NO LOAD POWER CONSUMPTION.	1
MAXIMUM BASEPLATE TEMPERATURE	100°C		1
TEMPERATURE STABILITY COEFFICIENT	0.02% / °C	OUTPUT VOLTAGE.	1
OUTPUT RIPPLE + NOISE (pk - pk)	< 0.5%	20MHz BANDWIDTH, Cout = 220uF	1
LINE REGULATION	< 1%	OUTPUT DEVIATION FOR \pm 20%, STEP CHANGE IN LINE VOLTAGE.	1
HOLD-UP TIME	0mSec	REQUIRES EXTERNAL HOLD-UP CAPACITOR. SEE APPLICATION NOTES FOR DETAILS.	1
MINIMUM OUTPUT CAPACITANCE	220uF	OBSERVE RIPPLE CURRENT REQUIREMENTS @ 800Hz & 125kHz FOR EXTERNAL OUTPUT CAPACITORS. SEE APPLICATION NOTES FOR DETAILS.	1
MAXIMUM OUTPUT CAPACITANCE	1,380uF	SPECIFIED IN ORDER NOT TO OVERSTRESS THE INTERNAL ACTIVE INRUSH CURRENT LIMITING CIRCUIT.	1
ISOLATION VOLTAGE: INPUT TO OUTPUT	NONE	NON-ISOLATED DEVICE. ISOLATION VOLTAGE IS ACHIEVED WITH DC/DC CONVERTERS.	1
ISOLATION VOLTAGE: INPUT/OUTPUT TO CHASSIS	1500V _{rms}	NO ARCING OR DAMAGE FOR 60 SECOND DURATION. 8mA _{rms} MAX LEAKAGE CURRENT.	2
SHORT- CIRCUIT PROTECTION	NONE	FUSE INPUT WITH SUITABLE FAST BLOW FUSE.	--
OVERVOLTAGE PROTECTION	OVP SET-POINT: 406V \pm 5%	OUTPUT VOLTAGE LIMITED, AUTO RECOVERY	1
20V _{bias} OUTPUT	17.8 \pm 2V _{dc}	REFERENCED TO Vrtn, MAXIMUM SOURCE CURRENT IS 5mA AT MODULE START-UP AND 12mA THEREAFTER UNLESS INCORPORATING START-UP ASSIST CIRCUIT (SEE APP NOTES). VOLTAGE MAY DROP BELOW 15.8V WHEN BOOST MODULE IS DISABLED OR LIGHTLY LOADED ON THE MAIN OUTPUT.	2

Notes:

1. Ensured by design, not 100% tested in production.
2. 100% tested for specification compliance in production.

To inquire about price and delivery please contact PPI's sales department.

ORDERING INFORMATION

PPI PART NUMBER: 82005 - - PbF

"H"	"F"
INTEGRAL FIN	FLAT TOP

