

# 82500

(250W, 47– 800Hz)

Low Profile

PFC Boost Converter Module



The **82500** module contains all of the necessary circuitry for complete power line compliance with aeronautics specification RTCA/DO-160G and Boeing's D6-36440(C)\*. It is a pin-for-pin and form-fit compatible drop-in replacement for the popular 80751E PFC boost module. Constructed using thermal circuit board technology and planar magnetics, these low profile (0.5" height) modules are compact and rugged. Providing line rectification, minimized input current harmonic distortion, active inrush current limiting and near unity power factor; the **82500** is ideal for avionics' applications where power demands are in the 125W-250W range.

The **82500** provides a standard 360Vdc output, compatible with a broad range of off-the-shelf DC/DC converter modules. Utilizing a modular approach, system power supplies are easily configured with a few individual components required. Tedious design and development cycles normally associated with custom power solutions are no longer necessary with this approach.

\* Requires external power line filter and hold-up capacitors; see typical application circuit and app notes for details

## FEATURES

	EXCEEDS BOEING'S RTCA/DO-160G, CATEGORY A(WF) FOR INPUT CURRENT HARMONIC DISTORTION LEVELS @ 360-800Hz
	EFFICIENCY: 91% TYPICAL
	WIDE INPUT RANGE: 96 - 134Vrms, 47 - 800Hz
	STANDARD 360Vdc OUTPUT COMPATIBLE WITH BROAD RANGE OF OFF-THE-SHELF DC/DC CONVERTER MODULES
	COMPLIES WITH RTCA/DO-160G EMI & SUSCEPTIBILITY (WITH EXTERNAL FILTER)
	VL94V-0 FLAMMABILITY CLASSIFICATION
	RUGGEDIZED SILICON-BASED ENCAPSULATED CONSTRUCTION WITH THERMAL CLAD TECHNOLOGY
	SIZE: 3.5" x 2.5" x 0.5", WEIGHT: 6oz.
	ACTIVE INRUSH CURRENT LIMITING
	OVERVOLTAGE AND THERMAL PROTECTION

## TEMPERATURE CHARACTERISTICS

*AIRFLOW (LFM)	THERMAL IMPEDANCE (0s-a) (°C/W)
0 LFM	5.50
250 LFM	1.50
500 LFM	0.90

\* Air velocity measured using a digital anemometer positioned within an airflow duct 4" X 3" above top of module

# 82500

## (250W, 47– 800Hz)

Low Profile

PFC Boost Converter Module



### PERFORMANCE SUMMARY

PARAMETER	SPECIFICATIONS
OUTPUT POWER RANGE (1,2)	125 - 250W
OUTPUT VOLTAGE (3)	360Vdc
MINIMUM EFFICIENCY (4)	88%
SWITCHING FREQUENCY	100kHz
MINIMUM OUTPUT CAPACITANCE (5)	100uF
INPUT LINE TO NEUTRAL CAPACITANCE (6)	0.28uF
TOTAL LINE/NEUTRAL TO CHASSIS CAPACITANCE (6)	4000pF
ISOLATION VOLTAGE, INPUT/ OUTPUT TO CHASSIS (7)	1500Vac
MTBF: Per RIAC 217Plus, Aic, 50°C operating temperature, 65% DC, 2190 Cycles/ yr.	2,440,000 Hours

NOTES:

1. Output power range in which module complies with RTCA/DO-160G, Category A(WF), with external filter.
2. Module is power limited at upper output limit (Pmax).
3. DC output voltage ± 3% when operating from no load through 150Wout (Pmax).
4. Minimum efficiency at Pmax. Efficiency is 91% typical.
5. Minimum output capacitance for proper boost module operation. Typical values will be larger to meet hold-up time requirements. Use polarized aluminum electrolytic type.
6. Capacitance tolerances are ± 20%.
7. 1500Vac, 60Hz for 60 seconds without arc or damage; 4mArms maximum leakage current (internal line-to-earth capacitors installed)

### SPECIFICATIONS

	RTCA/DO-160G, Section 4, Temperature, category A1 equipment, -15°C to 70°C operating (requires proper heatsinking)
	RTCA/DO-160G, Section 4, Category A1 equipment, Altitude: 15,000 feet, Decompression: 55,000 feet, Overpressure: 170kPa
	RTCA/DO-160G, Section 5, Temperature variation, category C (requires proper heatsinking)
	RTCA/DO-160G, Section 6, Humidity, category A
	RTCA/DO-160G, Section 7, Shock (operating) category B
	RTCA/DO-160G, Section 8, Vibration (operating) category S, curve B
	RTCA/DO-160G, Section 16, Power input requirements for category A(WF) equipment (requires external hold-up capacitors)
	RTCA/DO-160G, Section 17, Voltage spike, category A
	RTCA/DO-160G, Section 18, Audio frequency conducted susceptibility, category R(WF) equipment
	RTCA/DO-160G, Section 19, Induced signal susceptibility, category ZW
	RTCA/DO-160G, Section 20, Conducted and radiated susceptibility, category T, R
	RTCA/DO-160G, Section 21, Conducted and radiated emissions, category M (requires external filtering per application notes)

# 82500

## (250W, 47– 800Hz)

Low Profile

PFC Boost Converter Module



### BLOCK DIAGRAM

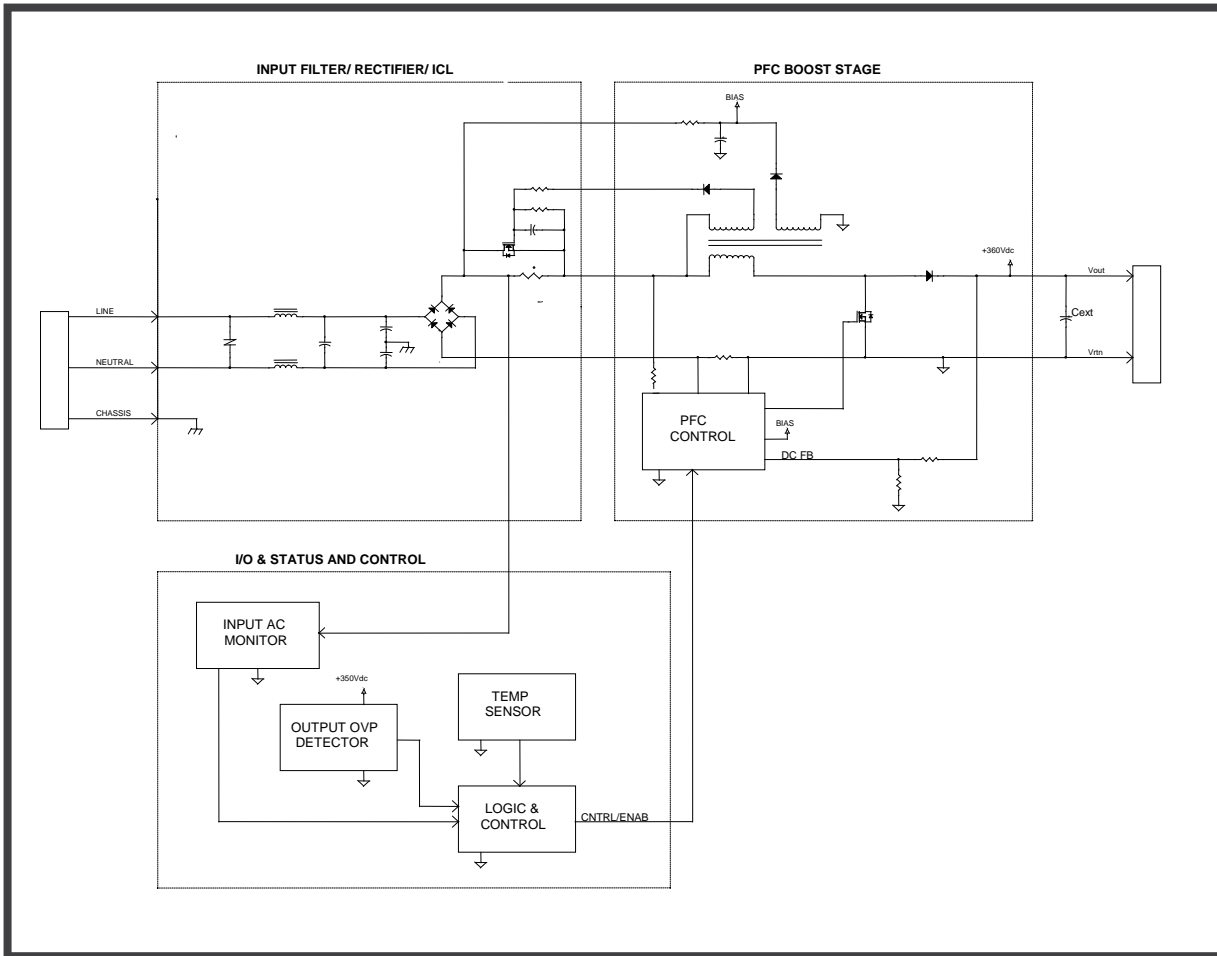

### TYPICAL APPLICATION CIRCUIT

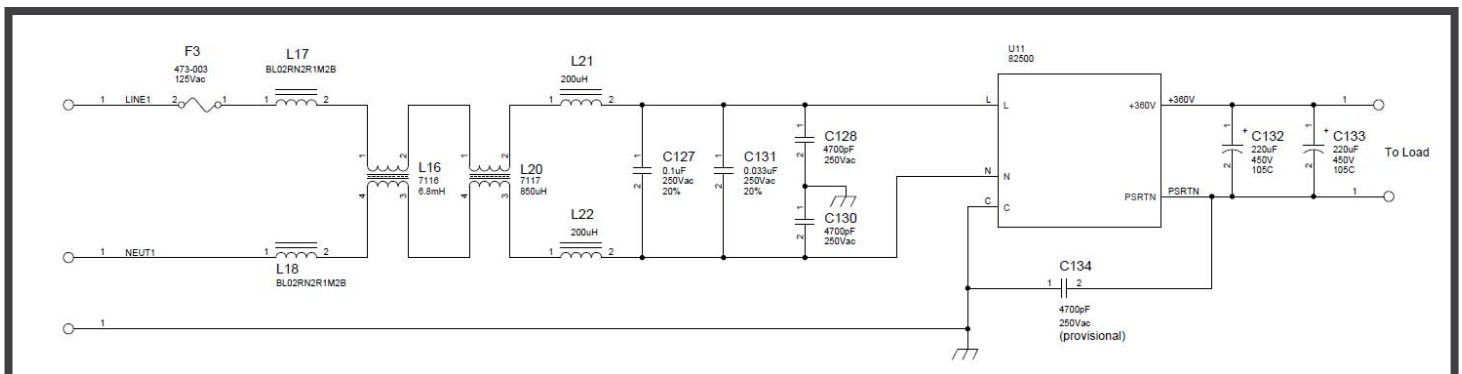

# 82500

## (250W, 47– 800Hz)

Low Profile

PFC Boost Converter Module



### MECHANICAL DIAGRAM

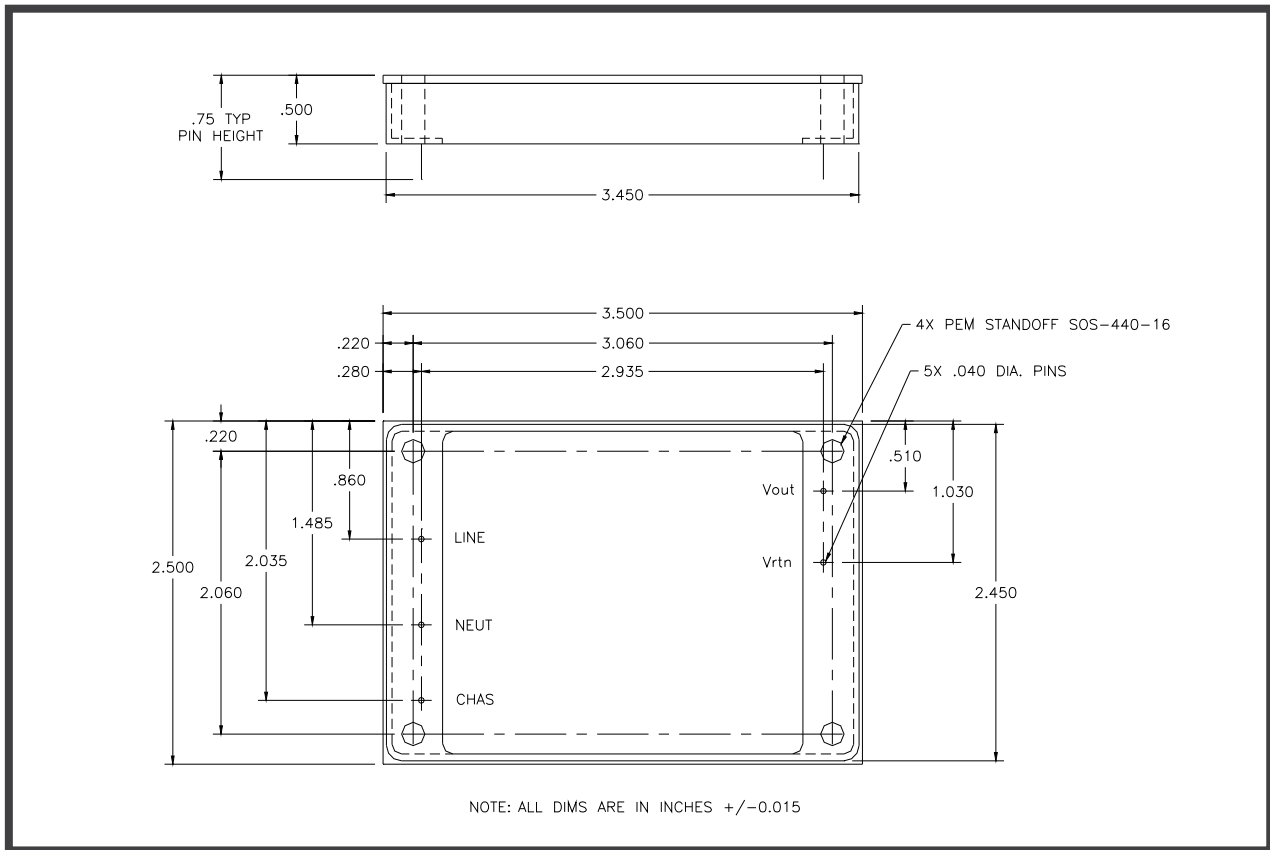

**A DETAILED OUTLINE DRAWING OR SOLID WORKS CAN BE FURNISHED UPON REQUEST.**

# 82500

## (250W, 47– 800Hz)

Low Profile

PFC Boost Converter Module



## ELECTRICAL SPECIFICATIONS

UNLESS OTHERWISE SPECIFIED THE FOLLOWING TEST CONDITIONS APPLY:  $T_A=25^{\circ}\text{C}$ . CONSTANT ACTIVE LOAD APPLIED TO OUTPUT IN PARALLEL WITH 470uF CAPACITOR.  $V_{IN}=115\text{V}_{\text{rms}}$ , 400Hz, < 1% THD SINUSOID.

## INPUT CHARACTERISTICS

PARAMETER	82500	REMARKS	NOTES
INPUT VOLTAGE RANGE	96 - 134Vrms	COMPLIES WITH NORMAL/ABNORMAL INPUT VOLTAGES PER RTCA/DO-160G, SECTION 16	2
INPUT FREQUENCY RANGE	47 - 800Hz	COMPLIES WITH DO-160G, SECTION 16, FOR A(WF) EQUIPMENT. OPERATES AT 47 - 360Hz WITH REDUCED DISTORTION PERFORMANCE	2
CONTINUOUS OUTPUT POWER	250W	OBSERVE 100°C MAXIMUM BASEPLATE TEMPERATURE	2
LEAKAGE CURRENT	< 5mA <sub>rms</sub>	AC LINE/NEUTRAL TO CHASSIS, $V_{in}$ @ 115Vrms, 400Hz	1
INRUSH CURRENT	< 7A <sub>pk</sub>	COLD START, $V_{out} = 0\text{Vdc}$	2
TOTAL HARMONIC DISTORTION (INPUT CURRENT)	< 5.5%	$P_{out} \geq 125\text{W}$	2
INDIVIDUAL HARMONICS - AC CLEAN (with app note filter)	EVEN: < 1% $I_f / n$ , ( $n < 10$ ) EVEN: < 0.1% $I_f$ , ( $n \geq 10$ ) ODD: < 30% $I_f / n$ ODD TRIPLES: < 15% $I_f / n$	$V_{in} = 115\text{V}_{\text{rms}}$ , 360 - 800Hz $V_{thd} \leq 1\%$ $n = \text{ORDER OF HARMONIC, 1 THRU 40}$ ; $I_f = \text{FUND CURRENT}$ $P_{out} \geq 125\text{W}$ and INDIVIDUAL HARMONICS > 10mA <sub>rms</sub>	1
INDIVIDUAL HARMONICS - DISTORTED INPUT (with app note filter)	EVEN: < 1% $I_f / n + V_n$ ( $n < 10$ ) EVEN: < 0.1% $I_f + V_n$ ( $n \geq 10$ ) ODD: < 30% $I_f / n + V_n$ ODD TRIPLES: < 15% $I_f / n + V_n$	$V_{in} = 115\text{V}_{\text{rms}}$ , 360 - 800Hz $V_{thd} \geq 10\%$ , $V_n = \text{CORRESPONDING INPUT VOLTAGE HARMONIC}$ $n = \text{ORDER OF HARMONIC, 1 THRU 40}$ ; $I_f = \text{FUND CURRENT}$ $P_{out} \geq 125\text{W}$ and INDIVIDUAL HARMONICS > 10mA <sub>rms</sub>	1
POWER FACTOR (with app note filter)	0.98 min	$P_{out} > 125\text{W}$ at 400Hz, $P_{out} > 150\text{W}$ at 800Hz.	2
CREST FACTOR (CURRENT)	1.314 - 1.514	RATIO OF PEAK/RMS	1
START-UP TIME	< 1Sec	$V_{out} > 200\text{Vdc}$	2
CONDUCTED EMISSIONS	RTCA/DO-160G CATEGORY M	REQUIRES EXTERNAL FILTER, SEE APPLICATION NOTES	1
AUDIO FREQUENCY CONDUCTED EMISSIONS	D6-16050-4 INDUCTIVE COUPLING PER SECTION 8.3.2	INPUT POWER LINES (with app note filter installed)	1
OPERATING TEMPERATURE RANGE	-25°C TO 100°C	BASEPLATE	1
STORAGE TEMPERATURE RANGE	-55°C TO 100°C	NON-OPERATIONAL	1
OVERTEMPERATURE PROTECTION	100°C +10, -5°C	BOOST INHIBITED WHEN OVERTEMPERATURE FAULT IS DETECTED. DURING INHIBIT, MODULE OUTPUT OPERATES AT $\sqrt{2} \cdot V_{in}$ (rms). AUTO RESET WITH ~ 15°C HYSTERESIS	1

Notes:

1. Ensured by design, not 100% tested in production.
2. 100% tested for specification compliance in production.

# 82500

## (250W, 47– 800Hz)

Low Profile

PFC Boost Converter Module



### OUTPUT CHARACTERISTICS

PARAMETER	82500	REMARKS	NOTES
RATED OUTPUT VOLTAGE	360Vdc+/-3%	$0W \leq P_{out} \leq 250W$	2
MINIMUM OUTPUT CURRENT	0A <sub>dc</sub>		2
MAXIMUM BASEPLATE TEMPERATURE	100°C		1
TEMPERATURE STABILITY COEF.	0.02% / °C	OUTPUT VOLTAGE	1
OUTPUT RIPPLE + NOISE (pk - pk)	< 0.5%	20MHz BANDWIDTH, C <sub>out</sub> = 470uF	1
LINE REGULATION	< 1%	OUTPUT DEVIATION FOR ± 20%, STEP CHANGE IN LINE VOLTAGE	1
HOLD-UP TIME	0mSec	REQUIRES EXTERNAL HOLD-UP CAPACITOR, SEE APPLICATION NOTES	1
MINIMUM OUTPUT CAPACITANCE	100uF	OBSERVE RIPPLE CURRENT REQUIREMENTS @ 800Hz & 100kHz FOR EXTERNAL OUTPUT CAPACITORS	1
MAXIMUM OUTPUT CAPACITANCE	1,200uF	SPECIFIED IN ORDER NOT TO OVERSTRESS THE INTERNAL ACTIVE INRUSH CURRENT LIMITING CIRCUIT	1
ISOLATION VOLTAGE: INPUT TO OUTPUT	NONE	NON-ISOLATED DEVICE, ISOLATION VOLTAGE IS ACHIEVED IN DC/DC CONVERTERS	1
ISOLATION VOLTAGE: INPUT/OUTPUT TO CHASSIS	1500Vac / 60Hz	NO ARCING OR DAMAGE FOR 60 SECOND DURATION 4mArms MAX LEAKAGE CURRENT	2
SHORT-CIRCUIT PROTECTION	NONE	FUSE INPUT WITH 3A FAST BLOW FUSE	1
OVERVOLTAGE PROTECTION	OVP SET-POINT: 405V ± 2%	OUTPUT VOLTAGE LIMITED, AUTO RECOVERY	1

Notes:

1. Ensured by design, not 100% tested in production.
2. 100% tested for specification compliance in production.