

84005-800

(90—260Vac; 47—800Hz)

400W, Single Phase, Universal Input,
PFC Boost Converter Module



The **84005-800** PFC boost converter module, when configured with external filter and hold-up capacitors, contains all the circuitry necessary for complete power line compliance with aeronautics specification RTCA/DO-160E and Airbus ABD0100.1.8 issue D, over the wide input frequency range (A(WF)). Housed within a 5-sided aluminum enclosure, the **84005-800** is embedded with a high quality silicon-based thermal encapsulant facilitating optimum performance within the harshest environments. Providing line rectification, minimized input current harmonic distortion content, active inrush current limiting and near unity power factor; the **84005-800** is ideal for avionics' applications where power demands are in the 180W-400W range.

The **84005-800** will operate from virtually any single phase AC power source worldwide. It provides a standard 360Vdc output compatible with a broad range of off-the-shelf DC/DC converter modules. Utilizing a modular approach, system power supplies are easily configured with a few individual components required. Tedious design and development cycles normally associated with custom power solutions are no longer necessary with this approach. Reliable, compliant power supplies can be configured in weeks, not months, without the need for specialized Power Supply Engineers.



FEATURES

	EXCEEDS AERONAUTICS' SPECIFICATION RTCA/DO-160E, SECTION 16, AND AIRBUS SPECIFICATION ABD0100.1.8, ISSUE D, FOR POWER FACTOR AND INPUT CURRENT HARMONIC DISTORTION LEVELS @ 360 - 800Hz
	UNIVERSAL INPUT VOLTAGE: 90 - 260Vrms; 47 - 800Hz
	STANDARD 360Vdc OUTPUT COMPATIBLE WITH BROAD RANGE OF <i>OFF-THE-SHELF</i> DC/DC CONVERTER MODULES
	COMPLIES WITH RTCA/DO-160E, CATEGORY M FOR CONDUCTED EMISSIONS & SUSCEPTIBILITY (WITH EXTERNAL FILTER)
	FULL LOAD EFFICIENCY: 89% TYPICAL @ 115Vrms INPUT; 94% TYPICAL @ 240Vrms INPUT
	VL94V-0 FLAMMABILITY CLASSIFICATION
	RUGGEDIZED SILICON-BASED ENCAPSULATED CONSTRUCTION
	SIZE: 5.41" x 2.98" x 1.68", WEIGHT: 32oz.
	ACTIVE INRUSH CURRENT LIMITING
	OVERVOLTAGE AND THERMAL PROTECTION

84005-800

(90—260Vac; 47— 800Hz)

400W, Single Phase, Universal Input,
PFC Boost Converter Module



TEMPERATURE CHARACTERISTICS (TYPICAL)

*AIRFLOW (LFM)	THERMAL IMPEDANCE (Θ_{s-a}) (°C/W)
0 LFM	1.60
250 LFM	0.73
500 LFM	0.56

* Air velocity measured using a digital anemometer positioned within an airflow duct 4" X 3" above top of module

EFFICIENCY CURVES (TYPICAL)

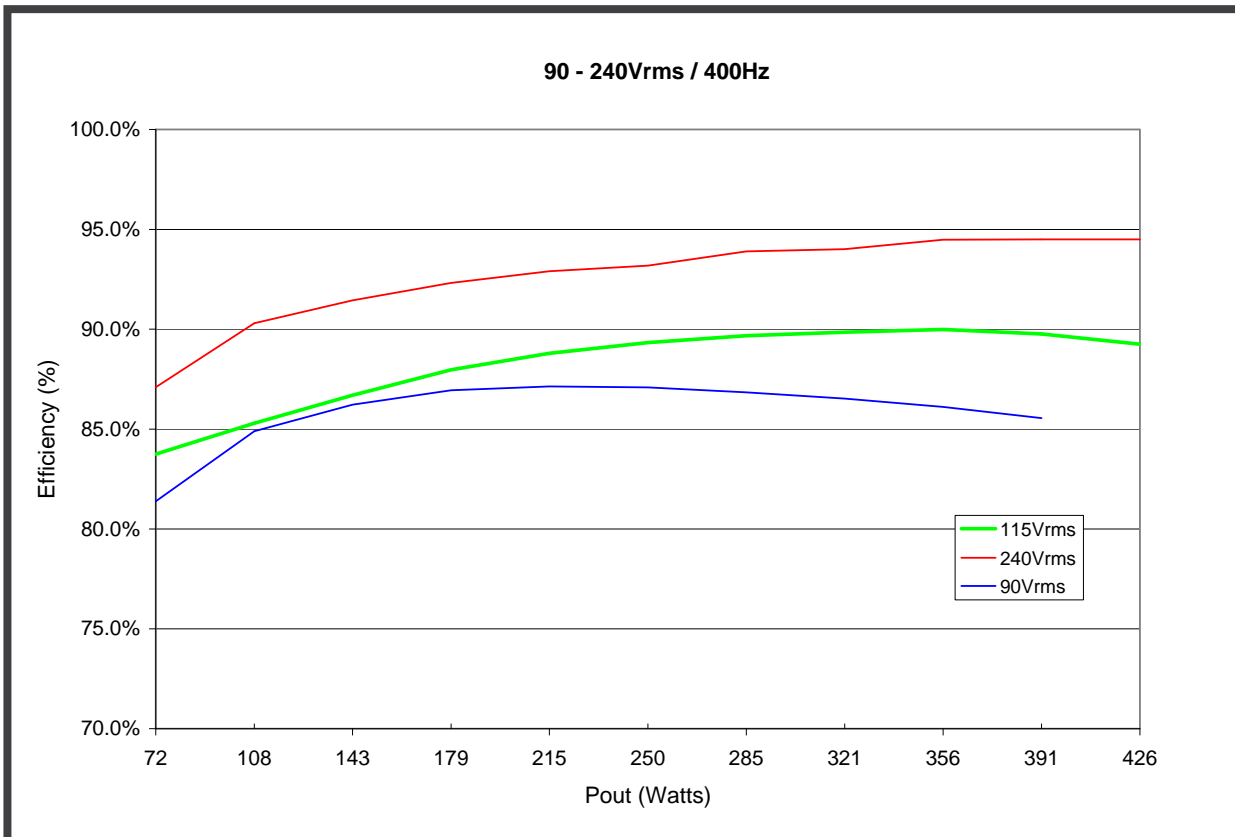

84005-800

(90—260Vac; 47—800Hz)

400W, Single Phase, Universal Input,
PFC Boost Converter Module



ELECTRICAL SPECIFICATIONS

UNLESS OTHERWISE SPECIFIED THE FOLLOWING TEST CONDITIONS APPLY: $T_A=25^{\circ}\text{C}$. COMBINATION OF CONSTANT ACTIVE AND RESISTIVE LOAD APPLIED TO OUTPUT IN PARALLEL WITH 470 μF CAPACITOR. INPUT VOLTAGE = 115Vrms, 400Hz, < 1.25% THD SINUSOID. INPUT FILTER INSTALLED ON INPUT AC LINES (SEE APPLICATION NOTES FOR DETAILS).

INPUT CHARACTERISTICS

PARAMETER	84005-800	REMARKS	NOTES
INPUT VOLTAGE RANGE	90 - 260Vrms	COMPLIES WITH NORMAL/ABNORMAL INPUT VOLTAGES PER RTCA/DO-160E, SECTION 16. MODULE REQUIRES EXTERNAL FILTER FOR PROPER OPERATION. SEE APP NOTES FOR DETAILS.	2
INPUT FREQUENCY RANGE	47 - 800Hz	COMPLIES WITH DO-160E, SECTION 16, FOR A(WF) EQUIPMENT. OPERATES AT 47 - 360Hz WITH REDUCED DISTORTION PERFORMANCE.	2
CONTINUOUS OUTPUT POWER	400W @ 97Vrms – 260Vrms 350W @ 90Vrms – 96Vrms	OBSERVE MAXIMUM BASEPLATE TEMPERATURE. MODULE REQUIRES EXTERNAL FILTER FOR PROPER OPERATION. SEE APP NOTES FOR DETAILS.	2
LEAKAGE CURRENT	< 5mA _{rms}	AC LINE/NEUTRAL TO CHASSIS, $V_{in} = 115\text{Vrms} / 400\text{Hz}$.	1
INRUSH CURRENT $V_{in} = 115\text{Vrms}$, 360Hz – 800Hz	8A _{rms} (11.3A _{pk})	COLD START, $V_{in} = 115\text{Vrms} / 400\text{Hz}$.	2
MAXIMUM INPUT CAPACITANCE	0.39 μF	LINE-TO-LINE, X2 CLASS	1
TOTAL HARMONIC DISTORTION (INPUT CURRENT)	5% maximum	115Vrms / 360Hz – 800Hz $V_{thd} \leq 1.25\%$ FOR ALL $P_{out} \geq 180\text{W}$	2
INDIVIDUAL HARMONICS - AC CLEAN	EVEN: < 1% I_f / n , ($n < 10$) EVEN: < 0.1% I_f , ($n \geq 10$) ODD: < 30% I_f / n ODD TRIPLENS: < 15% I_f / n	$V_{in} = 115\text{Vrms}$, 360Hz – 800Hz; WITH EXT FILTER (SEE APP NOTES). $V_{thd} \leq 1.25\%$ $n = \text{ORDER OF HARMONIC, 1 THRU 99}$; $I_f = \text{FUNDAMENTAL CURRENT}$ FOR ALL $P_{out} \geq 180\text{W}$ and INDIVIDUAL HARMONICS > 5mA _{rms}	1
INDIVIDUAL HARMONICS - DISTORTED INPUT	EVEN: < 1% $I_f / n + V_n$ ($n < 10$) EVEN: < 0.1% $I_f + V_n$ ($n \geq 10$) ODD: < 30% $I_f / n + V_n$ ODD TRIPLENS: < 15% $I_f / n + V_n$	$V_{in} = 115\text{Vrms}$, 360 - 800Hz; WITH EXT FILTER (SEE APP NOTES). $V_{thd} \geq 10\%$, $V_n = \text{CORRESPONDING INPUT VOLTAGE HARMONIC}$ $n = \text{ORDER OF HARMONIC, 1 THRU 99}$; $I_f = \text{FUNDAMENTAL CURRENT}$ FOR ALL $P_{out} \geq 180\text{W}$ and INDIVIDUAL HARMONICS > 5mA _{rms}	1
POWER FACTOR	0.90 min	$P_{out} > 150\text{W}$; WITH EXT FILTER (SEE APP NOTES).	2
CREST FACTOR (CURRENT)	1.314 - 1.514	RATIO OF PEAK/RMS	1
START-UP TIME (Tamb = 25°C)	< 1.8 Seconds	$V_{out} > 200\text{Vdc}$, $C_{out} = 3,000\mu\text{F}$, $P_{out} = 400\text{W}$	2
START-UP TIME (Tamb = -40°C)	< 14 Seconds	$V_{out} > 200\text{Vdc}$, $C_{out} = 3,000\mu\text{F}$, $P_{out} = 400\text{W}$	1
CONDUCTED EMISSIONS	RTCA DO160E, Section 21, Category M	REQUIRES EXTERNAL FILTER. SEE APP NOTES FOR DETAILS.	1

84005-800

(90—260Vac; 47— 800Hz)

400W, Single Phase, Universal Input,
PFC Boost Converter Module



INPUT CHARACTERISTICS—CONTINUED

PARAMETER	84005-800	REMARKS	NOTES
AMBIENT OPERATING TEMPERATURE RANGE	-40°C TO 70°C	ENCLOSURE TEMPERATURE. INTERNAL THERMOSTAT (90°C SET POINT) MAY ACTIVATE AT PROLONGED AMBIENT TEMPERATURES GREATER THAN 85°C AND HOLD FAULT CONDITION UNTIL THERMOSTAT RESETS. RESET HYSTERESIS IS BETWEEN 6°C AND 30°C OF INITIAL THERMOSTAT ACTIVATION TEMPERATURE.	1
AMBIENT STORAGE TEMPERATURE RANGE	-55°C TO 85°C	NON-OPERATIONAL.	1
MAXIMUM BASEPLATE TEMPERATURE	85°C	MAXIMUM ALLOWABLE SUSTAINED BASEPLATE TEMPERATURE WHEN OPERATING.	1
OVERTEMPERATURE PROTECTION	100°C ± 15°C	MODULE HOT SPOT TEMPERATURE WHILE THE MODULE IS OPERATING. HOT SPOT TEMPERATURE IS LOCATED ON THE SIDE OF THE MODULE ADJACENT TO THE FOUR COUNTERSUNK SCREWS. BOOST FUNCTION IS INHIBITED WHEN OVERTEMPERATURE FAULT IS DETECTED. DURING INHIBIT, MODULE OUTPUT OPERATES AT $\sqrt{2} \cdot V_{in}(rms)$. MODULE WILL AUTO RESTART AFTER COOLING DOWN.	1
UNDER-VOLTAGE DISABLE	84Vrms +/-5Vrms	BOOST FUNCTION IS INHIBITED 500mSec AFTER INPUT VOLTAGE IS SENSED BELOW THIS VALUE. DURING INHIBIT, MODULE OUTPUT OPERATES AT $\sqrt{2} \cdot V_{in}(rms)$.	2

84005-800

(90—260Vac; 47– 800Hz)

400W, Single Phase, Universal Input,
PFC Boost Converter Module



OUTPUT CHARACTERISTICS

PARAMETER	84005-800	REMARKS	NOTES
RATED OUTPUT VOLTAGE	360Vdc+/-3%	Cout ≥ 470uF, ALL LINE AND LOAD CONDITIONS.	2
MINIMUM OUTPUT CURRENT	0Adc		2
OUTPUT RIPPLE + NOISE (pk-pk)	< 0.5%	Cout ≥ 1500uF, 20MHz BW, ALL LINE AND LOAD CONDITIONS.	1
LINE REGULATION	< 1%	OUTPUT DEVIATION FOR ± 20%, STEP CHANGE IN LINE VOLTAGE. Cout ≥ 470uF.	1
HOLD-UP TIME	0mSec	REQUIRES EXTERNAL HOLD-UP CAPACITOR TO EXTEND SUPPLY LEVEL HOLD-UP TIME; SEE APPLICATION NOTES FOR DETAILS.	1
WARM START DELAY (AFTER MOMENTARY INPUT AC POWER INTERRUPTS)	50mSec	MAXIMUM TIME DELAY BETWEEN THE TIME THE INPUT IS REAPPLIED AND WHEN THE OUTPUT BEGINS TO CHARGE POSITIVE FOLLOWING MOMENTARY POWER INTERRUPTS OF LESS THAN 400mSec.	2
MINIMUM OUTPUT CAPACITANCE	470uF	OBSERVE RIPPLE CURRENT REQUIREMENTS @ 800Hz & 100kHz FOR EXTERNAL OUTPUT CAPACITORS.	1
MAXIMUM OUTPUT CAPACITANCE	5,000uF	SPECIFIED FOR Vin = 115Vac; DERATE TO 1,250uF MAXIMUM FOR Vin = 240Vac.	1
ISOLATION VOLTAGE INPUT/OUTPUT TO CHASSIS	1500Vac / 60Hz / 60 Seconds 8mArms max leakage current	INPUT "Y" SUPPRESSION CAPACITORS INSTALLED. LEAKAGE CURRENT FOR ANY INPUT OR OUTPUT TERMINAL TO CHASSIS TERMINAL (or enclosure). NO ARCING OR DAMAGE WILL OCCUR.	2
ISOLATION VOLTAGE INPUT/OUTPUT TO CHASSIS	1500Vac / 60Hz / 60 Seconds 800uArms max leakage current	INPUT "Y" SUPPRESSION CAPACITORS REMOVED. LEAKAGE CURRENT FOR ANY INPUT OR OUTPUT TERMINAL TO CHASSIS TERMINAL (or enclosure). NO ARCING OR DAMAGE WILL OCCUR.	1
SHORT-CIRCUIT PROTECTION	NONE	FUSE INPUT WITH 10A FAST BLOW FUSE.	1
AC POWER FAIL STATUS "ACPWRFAIL-L"	TRANSITIONS TO 0.5V MAXIMUM WHEN LOSS OF INPUT AC IS DETECTED	TTL LEVEL, 8mA MAX SINK CURRENT, 25mSec DELAY TIME TO ACTIVATE ON INPUT AC INTERRUPTS.	2
OVERVOLTAGE PROTECTION	OVP SET-POINT: 420V ± 2%	OUTPUT VOLTAGE LIMITED; AUTO RECOVERY. BOOST FUNCTION IS INHIBITED WHEN OUTPUT VOLTAGE IS SENSED AT THIS VALUE. DURING INHIBIT, MODULE OPERATES AT $\sqrt{2} \cdot V_{in}(\text{rms})$.	1

Notes:

1. Ensured by design, not 100% tested in production.
2. 100% tested for specification compliance in production.

84005-800

(90—260Vac; 47—800Hz)

400W, Single Phase, Universal Input,
PFC Boost Converter Module



WAVEFORM DATA

Start-Up Profile (115Vrms / 400Hz, Cout = 3,400uF, Pout = 400W)

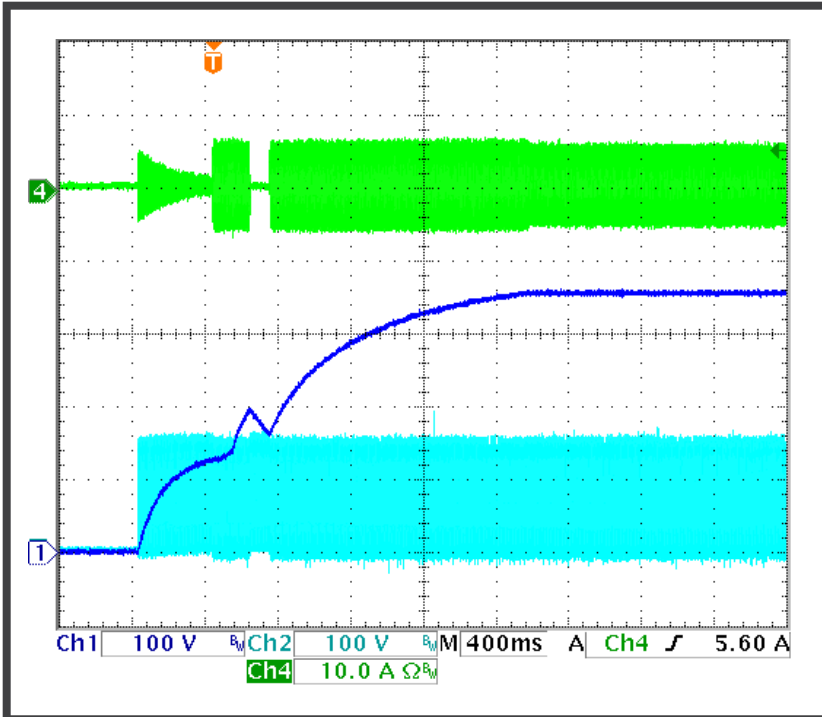

Input Current (CH4)

Output Voltage (CH1)

Input Voltage (CH2)

AC Interrupt = 200mSec (115Vrms / 400Hz, Cout = 3,400uF, Pout = 400W)

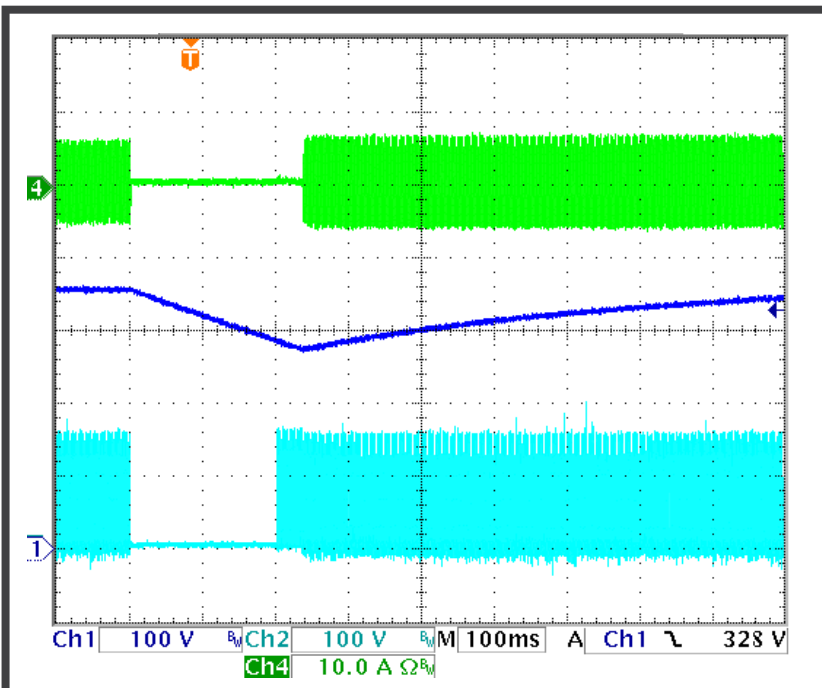

Input Current (CH4)

Output Voltage (CH1)

Input Voltage (CH2)

84005-800

(90—260Vac; 47—800Hz)

400W, Single Phase, Universal Input,
PFC Boost Converter Module



WAVEFORM DATA—CONTINUED

AC Interrupt = 800mSec (115Vrms / 400Hz, Cout = 3,400uF, Pout = 400W)

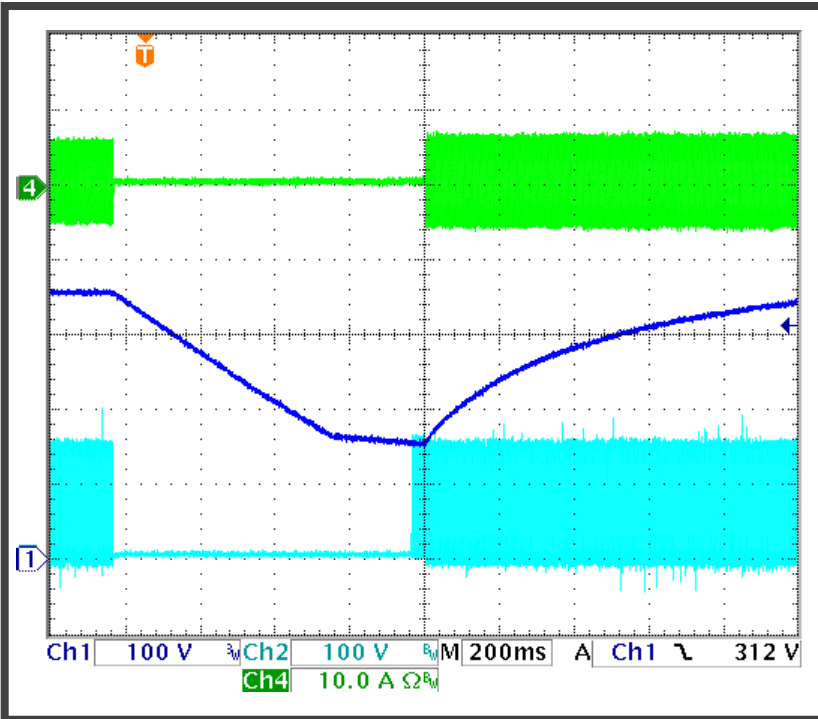

Input Current (CH4)

Output Voltage (CH1)

Input Voltage (CH2)

APPLICATION'S INFORMATION

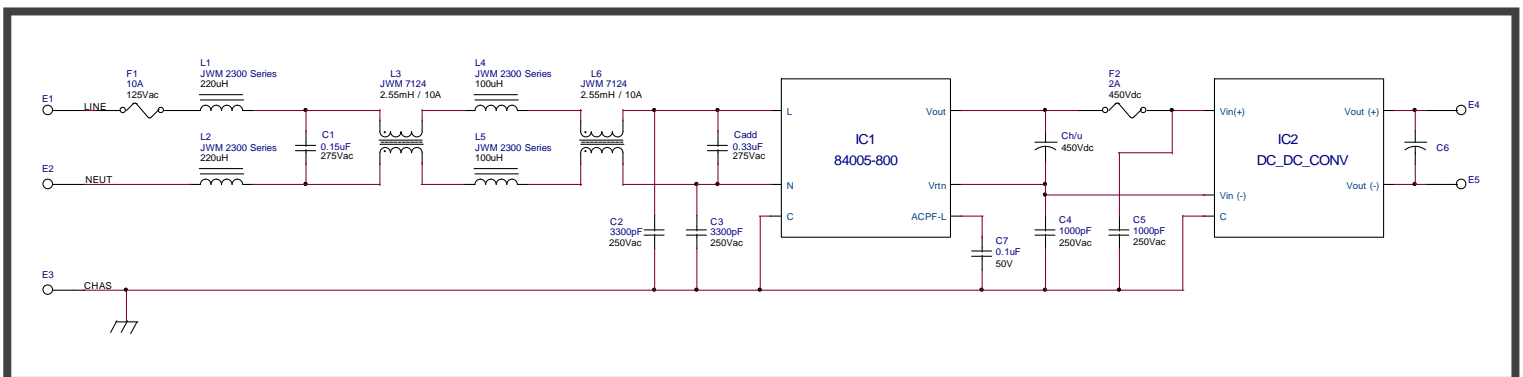

Typical Application Circuit

84005-800

(90—260Vac; 47– 800Hz)

400W, Single Phase, Universal Input,
PFC Boost Converter Module



HOLD-UP TIME

In order to extend configured power supply hold-up time, polarized 450V (minimum) electrolytic capacitors must be connected externally between the module's Vout and Vrtn pins. Required external capacitance can be determined using the following formula:

$$E = P * (t + t_{\text{restart}}) = \{ \frac{1}{2} C_{h/u} (V_i^2 - V_f^2) \}$$

Where,

P = External (downstream) DC/DC converter input power (Watts)

t = Desired hold-up time (Seconds)

t_{restart} = Warm start delay of approximately 40mSec (50mSec max) upon reapplication of input AC

C_{h/u} = External hold-up capacitance (Farads)

V_i = Minimum PFC output voltage = 360 Volts – 3% = 349.2V

V_f = Undervoltage shutdown level for downstream DC/DC converter (typically 180 Volts)

In order to hold up 300W boost converter output power for 200mSec requires:

$$C_{h/u} = \{ (300W) (200mSec + 40mSec) \} \div \{ (1/2) (349.2V^2 - 180V^2) \} = 1,610uF$$

Use of 105°C, 450Vdc, 20% tolerance snap-mount aluminum electrolytic capacitors is recommended. For the example above, a total nominal capacitance of 1,930uF would be necessary to assure the required capacitance of 1,610uF was achieved. Warm start delay occurs for AC power interrupts less than ~400mSec as a result of combination of time to reactivate PFC control circuitry, reinitiation of PFC soft-start cycle and reaching module power limit.

EXTERNAL FILTER

The 84005-800 module requires an external filter on the AC lines for specification compliance. The filter shown in the typical application circuit above may be used for all applications requiring up to approximately 250W output power. **For applications requiring between 250W and 400W output power, the filter shown in the application circuit with the addition of Cadd (0.33uF) is necessary to assure proper PFC boost module operation.**

EMI CONSIDERATIONS

Use of a chassis ground plane or aluminum surface beneath the non-metallic (silicon) module side is recommended. Although the 84005-800 module contains a differential mode input filter and common-mode suppression capacitors, the use of an external line filter is required for compliance with conducted emissions. See application circuit for suggested filter arrangement and values.

Assure the current ratings of the differential and common mode inductors are sufficient. Avoid adding excessive line-to-line capacitance at lower output power levels (<250W output) as this may have an adverse effect on input current harmonic distortion at higher line frequencies (e.g., 800Hz). **If using the module above 250W and up to the upper power limit of 400W out, additional line-to-line capacitance (e.g., 0.33uF) is required as shown by Cadd in the filter schematic for compliance with conducted emissions as well as for proper module operation.**

One or more of the external hold-up capacitors should be installed in close proximity to the module's output terminals (within 2 – 3 inches is recommended).

84005-800

(90—260Vac; 47– 800Hz)

400W, Single Phase, Universal Input,
PFC Boost Converter Module



SAFETY CONSIDERATIONS

The 84005-800 module does not contain internal overcurrent protection. An external fuse installed in the line is required to assure proper protection in the event of a short circuit or low impedance fault condition on the modules output terminals or within the module's input EMI filter. A properly rated slow-blow fuse should be selected and tested within the application to assure it protects the module and wiring in the event of a fault while not nuisance tripping when cycling input AC power (as a result of charging output hold up capacitors).

THERMAL CONSIDERATIONS

There is no derating required for module output power up to the module's maximum baseplate temperature of 85°C. Beyond this temperature the module will shutdown. In order to assure the baseplate temperature remains below 85°C additional heatsinking or forced airflow may be required. In order to estimate baseplate temperature and whether external heatsinking or airflow is necessary, apply the following formula:

$$T_{\text{baseplate}} = T_{\text{ambient}} + (P_{\text{diss}})(\Theta_{\text{s-a}})$$

Where:

$T_{\text{baseplate}}$ = Module baseplate temperature in °C,

T_{ambient} = Ambient air temperature in °C,

$\Theta_{\text{s-a}}$ = Thermal resistance from module baseplate to ambient air in °C/W without external heatsink,

eff = Module efficiency from appropriate curve,

$P_{\text{diss}} = \{(P_{\text{out}} \div \text{eff}) - P_{\text{out}}\}$ in watts

As an example,

Assume a desired output power of 400W at nominal line operation (115Vrms) with a maximum ambient temperature of 55°C. The following formula would apply:

$$T_{\text{baseplate}} = 55^{\circ}\text{C} + \{(400\text{W} / 0.89) - 400\text{W}\} (1.6^{\circ}\text{C}/\text{W}) = 134^{\circ}\text{C}$$

Therefore either an external heatsink would be required or forced airflow such that $\Theta_{\text{s-a}}$ was reduced to:

$$\Theta_{\text{s-a}} < \{(T_{\text{baseplate}} - T_{\text{ambient}}) \div P_{\text{diss}}\}$$

$$\Theta_{\text{s-a}} < \{85^{\circ}\text{C} - 55^{\circ}\text{C}\} \div \{(400\text{W} / 0.89) - 400\text{W}\} < 0.61^{\circ}\text{C}/\text{W}$$