

82500-PBF PFC BOOST MODULE

Application Information

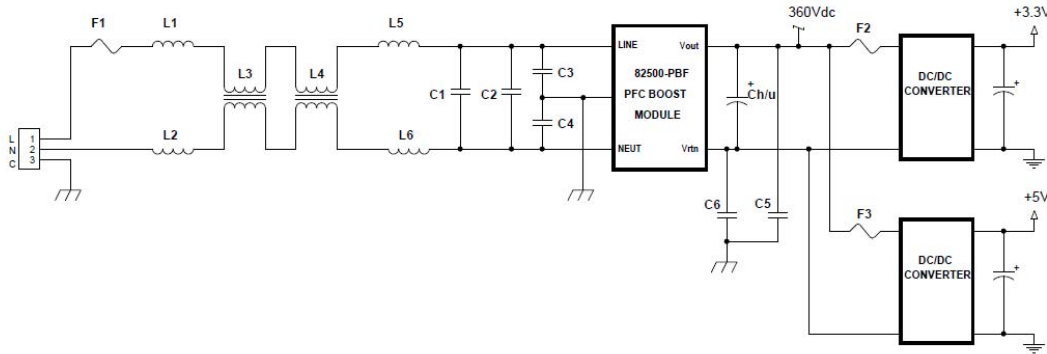

Figure 1. Typical Application Circuit, 3.3V & 5V, 200W Combined Output Power

Designator	P/N or Description
F1	3A, 125Vac, Slow-Blow
F2, F3	2.5A, 450V, PC-Tron
L1, L2	Inductors Inc., p/n KT-01-8487F (bead on lead)
L3	Bourns 7120-RC (6.8mH,4A)
L4	Bourns 7117 (850uH, 3A)
L5, L6	Bourns 2100LL-221-H-RC (220uH, 3.5A)
C1	0.10uF, 275Vac, "X2" rated
C2	0.033uF, 275Vac, "X2" rated
C3, C4	4700pF, 250Vac, "Y1/Y2" rated
C5, C6	1000pF, 250Vac, "Y1/Y2" rated (provisional)
Ch/u	450V, 105°C, Snap-Mount Electrolytic
IC1	PPI p/n 82500-PBF
IC2	COTS HV DC/DC Converter
IC3	COTS HV DC/DC Converter

OVERVIEW:

Implementing power factor correction (PFC) into switch mode power supplies maximizes the power handling capability of the power supply and current handling capacities of power distribution networks. Input power factor (PF) is defined as real power (Watts) divided by apparent power (VA) and is expressed as decimal number between 0 and 1. A non-corrected power supply with a typical PF equal to 0.65 will draw approximately 1.5 times greater input current as a PFC supply (PF=0.99) for the same output loading. The non-corrected supply requires additional AC current to be generated which is not consumed by the load, creating I^2R losses in the power distribution network.

Ideally, PFC power supplies "look" like a resistor to the driving voltage source; the current drawn by the supply matches the voltage in waveshape and phase. Power Factor will approach unity when the input current drawn by the power supply matches and is in phase with the input voltage. For a sine wave voltage source, the input current of a well-designed PFC supply will also be a sine wave. A perfect sine wave contains no harmonic distortion (all individual higher order harmonics have zero magnitude). As a result, a derivative of active power factor corrected power supplies, when subjected to a non-distorted input source, is minimization of input current harmonic distortion content.

Airborne equipment must comply with stringent standards regarding input power factor and input current harmonic distortion content. RTCA/DO160G section 16 and Boeing's D6-44588 require minimization of

individual harmonic distortion content up to the 40th harmonic (2kHz at 400Hz fundamental frequency) for all equipment that draws more than 35VA. Limits set forth in these specifications mandate active PFC correction for most airborne equipment power supplies. For a non-distorted single phase AC voltage source, individual input current harmonic distortion requirements are:

Harmonic Order	Limits
Odd triplen harmonics; (h = 3, 9, 15, 21, 27, 33, 39)	$I_h = 0.15(I_f) / h$
Odd non triplen harmonics; (h = 5, 7, 11, 13, 17, 19, 23, 25, 29, 31, 35, 37)	$I_h = 0.3(I_f) / h$
Even harmonics 2 & 4; (h = 2 and 4)	$I_h = 0.01(I_f) / h$
Even harmonics > 4; (h = 6, 8, ... 40)	$I_h = 0.0025(I_f)$

Where:

h = order of harmonic

I_h = maximum harmonic current of order h obtained during min, max and steady state operation

I_f = fundamental current obtained during min, max and steady state operation

Individual harmonic currents < 10mA_{rms} are disregarded (<5mA_{rms} for DO160G)

Requirements were added some time back to these specifications that require test and compliance with input harmonic distortion for variable frequency generators from the minimum input line frequency of 360Hz through the maximum input line frequency of 800Hz.

A block diagram of an active PFC boost converter is shown in figure 2. The input stage of this type of converter is the same as a conventional non-corrected power supply; the input AC is filtered and rectified. In order to boost the output and to control the input current, the large input capacitor that would normally be associated with the AC to DC conversion function has been moved to the output of the boost converter; C_{out} in the diagram. The PFC controller circuitry programs the input current to track the input voltage by varying the main MOSFET duty cycle based on two feedback and one feedforward signals: output voltage, rectified line current and rectified AC voltage. The output of the boost regulator is a constant voltage but the input current is programmed to be a half sine wave. The power flow into C_{out} is a sine wave at twice the line frequency.

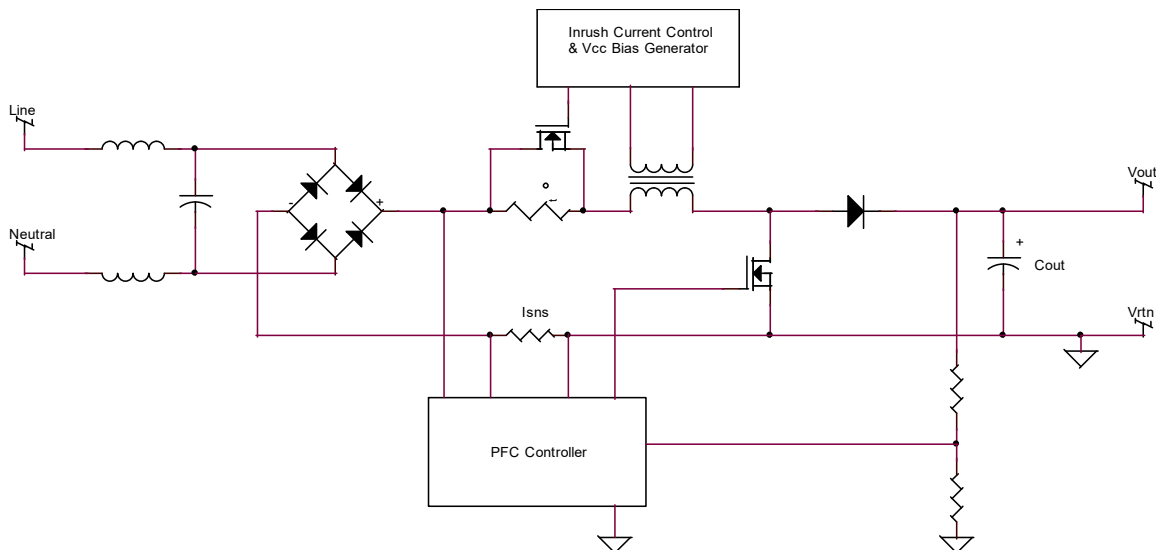

APPLICATION CIRCUIT

A schematic of a typical PFC, dual output 3.3V and 5V modular power supply is provided in figure 1. A modular supply of this type is practical for one, two or three outputs and can accommodate any isolated output voltage from 2V to 48V. There are a variety of compatible DC/DC converters available off the shelf

that can operate from a 360Vdc bus. The downstream DC/DC converters must be capable of operating from a high voltage input, typically between 180Vdc and 400Vdc. As the number of outputs is increased beyond three, it is often more cost effective and space effective to incorporate a discrete power supply.

When configured properly, the PFC modular supply depicted in figure 1 will operate from a 115Vrms, single phase, 47Hz – 800Hz input source and will provide approximately 200W combined output power. Provided sufficient output hold-up capacitance (Cout) is incorporated, the supply will comply with all the input power requirements per RTCA/DO-160G, section 16 for the wide variable frequency category A(WF). This includes normal and abnormal operating conditions for AC equipment as well as the A(WF) limits for input harmonic distortion.

Supply hold-up time is selectable by implementation of high voltage electrolytic capacitors (Cout) connected at the output terminals of the PFC converter module. For applications requiring higher output power levels, the PFC converter module can be substituted for one offering higher power capacity.

COMPONENT SELECTION:

EXTERNAL EMI FILTER

An external power line filter is necessary when implementing the 82500-PBF series PFC boost module into a modular supply for compliance with RTCA/DO-160G conducted emissions requirements. The filter shown in the application circuit above, in cascade with the normal-mode filter internal to the 82500-PBF module, will suppress conducted emissions to levels below DO-160G requirements. The external filter should be placed as close as possible to the AC entry point within assembly (i.e., at the power connector). The addition of L1-L4 and C3-C6 will have minimal impact on harmonic distortion performance of the 82500-PBF boost module while the differential portion of the filter (comprised of L5, L6, C1 and C2) will have an adverse effect on harmonic distortion levels. The value of C1+C2 needs to be kept small (on the order of 0.047uF per 75W of input power) in order to minimize the impact on individual harmonic distortion levels when subjecting the supply to input voltage distortion greater than 10% (Vthd), particularly at 800Hz. The configured modular supply with external filter should be evaluated for harmonic and emissions performance within the application prior to finalizing component values. Differential inductors, L5 and L6, if constructed with iron powder cores can cause problems with 3rd harmonic input current distortion. Sendust or MPP core materials are better suited in this location.

HOLD-UP CAPACITOR(S) (Ch/u)

The 82500-PBF PFC boost converter requires a minimum output capacitance of 220uF for proper module operation. Typical values will be larger due to the hold-up time requirements of the particular application. If loading the output of the converter, a minimum of 220uF of output capacitance must be established through a low impedance connection to the output terminals of the module or the module's output will not regulate properly. Failure to maintain this minimum capacitance while loading the output can result in permanent damage to the 82500-PBF module.

The 82500-PBF module's maximum allowable output capacitance is 1200uF. If exceeding this value, proper module start-up during full load at low input line may be compromised and should be verified. When incorporating larger values of output capacitors and using DC/DC converters that turn-on at voltages well below the module's rated output voltage, verify proper modular supply start-up at low line input voltages. The module's output power limit set point (~300Wout) can be exceeded due to the combination of charging the output capacitor bank and driving the DC/DC converter load causing cyclic on/off of the boost module when starting at low line. This condition can be corrected by delaying the DC/DC converter at start-up until the boost module is at or near its specified output voltage, or selecting a higher power front-end boost converter module.

Recommended Hold-up Capacitor Type and Placement:

- United Chemi-Con, KMQ series, 450V, 105°C, Snap-mount
- Panasonic, TS-HC series, 450V, 105°C, Snap-mount
- Nichicon, GJ Series, 450V, 105°C, Snap-mount, 20mm height

Placement:

Output capacitor(s) should be placed within several inches of the boost module output prior to the DC/DC converter input fuses, F2 and F3.

Output Capacitor Ripple Requirements:

Observe capacitor ripple current requirements at 800Hz and 100kHz (when operating at 400Hz input frequency). Normal full load 800Hz ripple current can be approximated by:

$$I_{800} \sim P_{in} / V_{in} \text{ (rms)}$$

100kHz ripple current content is generated as a function of the boost module's normal operation. The maximum 100kHz ripple current for the 82500-PBF series is 900mA_{pk-pk} and occurs at the internal switching frequency of the converter.

Hold-up Time Calculations:

Output capacitance (C_{out}) vs. hold-up time (t) can be calculated by the following formula:

$$E = P(t + t_{wsd}) = 1/2C_{out}(V_i^2 - V_f^2)$$

where:

P = Power delivered to DC/DC converters

t_{wsd} = Warm Start Delay time, delay of approximately 40mSec (50mSec maximum) upon reapplication of input AC prior to module regaining boost function

V_i = Normal operating DC output voltage of boost converter (360Vdc)

V_f = Minimum operating voltage of DC/DC converter

FUSES

Properly fusing the input line is necessary for safeguarding against a catastrophic failure within the input filter capacitors, the 82500-PBF boost module, the output electrolytic capacitors (C_{out}) or the DC/DC converters. The 82500-PBF PFC boost module does not contain overcurrent protection; if a short circuit or low impedance condition is applied across its output terminals, there is no internal current limiting feature. The topology of a boost converter (see figure 2) is such that it resorts back to a standard rectifier/ bulk capacitor front-end when the boost function is inhibited. For this reason, without implementing elaborate current sensing and protection circuitry in the rectified line, the boost converter is inherently not protected against shorted or low impedance output conditions.

Fusing the DC/DC converter input lines is necessary for safeguarding against a catastrophic DC/DC converter failure. Although the input line fuse will eventually activate, DC fuses positioned right at the input to the DC/DC converters will limit the energy delivered by the hold-up capacitors (C_{out}) and will prevent secondary overcurrent stress and/or failure to the PFC boost module.

Fuse charts (I versus t) should be examined to verify that the line fuse selected will not prematurely activate as a result of normal inrush currents flowing at supply start-up. Inrush current is limited within the 82500-PBF module to 5A_{pk} (3.54A_{rms}) by an active inrush current limiting circuit. Inrush current duration (t) increases with increasing output capacitance (C_{out}) and can be approximated by t = (50) × (C_{out}).

F1 = 3A, 125Vac, Slow-Blow

F2 = F3 = Bussmann, PC-Tron, DC Fuse, PCB Series, 450V/2.5A

EMI CONSIDERATIONS

Certain measures should be taken to assure successful EMI compliance. Among these are:

- Use of solid chassis ground plane on power supply PCB
- Solid mechanical interconnection from chassis ground to module frame (#4 hardware, 4 places)
- Incorporation of suggested external line filter
- Observance of EMI guidelines for specific DC/DC converters chosen
- Avoidance routing traces directly under module

EFFICIENCY & POWER CONSUMPTION

Typical efficiency for the 82500-PBF converter module is 90%. For maximum output power of 250W, the 82500-PBF will dissipate approximately 28W. Quiescent power consumption is 2W (at no output load). When determining 82500-PBF temperature rise, power consumption can be calculated or measured and multiplied by the thermal resistance from module baseplate to ambient. See the thermal table in the 82500-PBF data sheet for coefficients versus airflow.

When computing overall modular power supply efficiency the boost converter efficiency must be multiplied by the downstream DC/DC converter efficiencies. When computing energy requirements for the hold-up capacitors, only the efficiency of the DC/DC converters needs to be considered.

The 82500-PBF contains an internal power limit feature to assure the module's internal switching (power stage) circuitry is not overstressed when load demands are higher than the module's rated output power. The power limit set-point is approximately 300W. Load demands exceeding this value will cause the module's output voltage to foldback; the internal boost converter duty cycle will reduce proportional to the overload demand in order to keep the output power constant and limited. This feature does not safeguard against a shorted output – the input line must be properly fused to protect the module's internal bridge rectifier and AC current sensing circuitry.

PRECAUTIONS

ISOLATION

The 82500-PBF PFC boost module is a non-isolated device. The output is a 360Vdc differential potential but not with respect to chassis ground. The 360V return line (Vrtn) is not at chassis potential. Isolation (primary to secondary) is accomplished within the DC/DC converters. Special care must be exercised when monitoring the module's DC output on an oscilloscope. Either the oscilloscope must be floated from chassis ground or the input neutral line disconnected from chassis ground. Typical aircraft application is to tie neutral and chassis ground together. Failure to isolate neutral from the module's return line can permanently damage the boost module device. Proper input fusing of the AC high line should protect the boost module in the event the neutral is inadvertently tied to the module's return line (i.e., during testing).

PRIMARY-TO-SECONDARY ISOLATION

Primary to secondary isolation for the configured supply is achieved within the DC/DC converters. Typically, the level of isolation provided within the DC/DC converter is more than sufficient for airborne applications; airborne specifications require 1500Vrms primary to secondary isolation. It is imperative from a safety standpoint to avoid commingling input AC referenced circuitry from DC output secondary referenced circuitry. A general guideline is to maintain at least 4mm creepage/clearance distance between any primary referenced circuit and any secondary referenced circuit.

THERMAL CONSIDERATIONS

The maximum baseplate temperature rating for the 82500-PBF module is 100°C. There is no derating required; the module can supply full output power up to the maximum baseplate temperature. The modules contain overtemperature protection, it is activated at a sensed baseplate temperature exceeding 100°C. When activated, the module's boost function is inhibited. During this time the module's output voltage will be ~162Vdc depending on output loading. This level is typically below the input operating threshold of the downstream DC/DC converters thus disabling all low-level outputs during an overtemperature fault. Module recovery is automatic with ~15°C hysteresis.