

# PFC100W-28VPN-PBF

(115Vac, 47- 800Hz Input)

100W, 28V/ 3.6A Single Output,

Airborne PFC Power Module

# PRELIMINARY



Targeting low power avionics' applications, the **PFC100W-28VPN-PBF** module provides an isolated 28Vdc output with an integral PFC input converter stage. It meets the most stringent airborne requirements including those for variable frequency 115Vac generator systems over the wide frequency range of 360-800Hz and RTCA/DO-160G category M emissions.

Utilizing thermal-clad circuit board technology and low profile planar magnetics, thermal gradients between heat dissipating components and the module baseplate are minimized while maintaining a low 0.75" profile. Standard protection features are built-in in to assure years of fault-tolerant and reliable operation in the harshest environments.







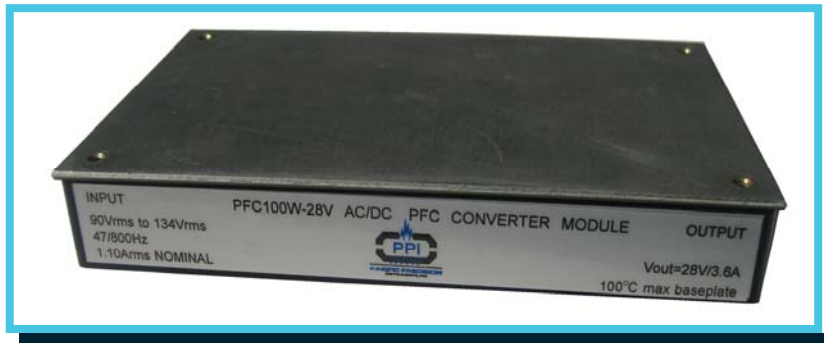







The **PFC100W-28VPN-PBF** is capable of providing uninterrupted ride-through at full output load during momentary input AC brown-out conditions for up to 5mSec. Hold-up time is readily expanded by connecting external electrolytic capacitors to the PFC output pins provided.

Weighing less than 16 ounces, the **PFC100W-28VPN-PBF** is housed in a silicon-based encapsulated enclosure with outer dimensions of 5.0" x 3.0" x 0.75". Four corner mounting holes are included to facilitate system mounting. The **PFC100W-28VPN-PBF** is intended for low-profile PCB mount applications where the topside baseplate can be flush mounted to LRU chassis sidewalls or a stand-alone heatsink.

The **PFC100W-28VPN-PBF** is tuned to limit input power to 170W +/-6W in order to limit inrush current.



## FEATURES

	Meets both RTCA/DO-160G, section 16, and Airbus ABD0100.1.8 issue D for power factor and input current harmonic distortion levels over the wide frequency operating range (360Hz – 800Hz) at ½ to full rated load
	Wide input range: 96Vrms – 134Vrms, 47 – 800Hz
	Complies with RTCA/DO-160G for conducted emissions, susceptibility and power input (section 16), see sheet 2, note 7
	Active inrush current limiting: 5Apk typical, 7Apk maximum
	Size: 5.0" x 3.0" x 0.75", Weight: less than 16 ounces
	Tightly regulated isolated output: 28V / 3.6A
	Overcurrent protection with pulse retry current limiting
	Two independent overvoltage protection circuits. 33V "soft" with auto restart, 36V "hard" latching with AC reset required
	PFC output overvoltage protection with automatic restart (internal 200Vdc PFC output)
	Over-temperature shutdown with automatic restart (baseplate at or above 100°C)
	DC output valid status line (TTL)
	AC valid status line (TTL)
	Remote sense capability
	MTBF: 571,000 Hours (RAIC 217Plus, Aic, 50°C operating temperature, 65% DC, 2190 Cycles/ yr.)

# PFC100W-28VPN-PBF

(115Vac, 47- 800Hz Input)

100W, 28V/ 3.6A Single Output,

Airborne PFC Power Module



## PERFORMANCE SUMMARY

PARAMETER	SPECIFICATIONS
Voltage regulation	+28Vdc +/-2%
Rated output current	3.6A
Minimum load	0A
Pk-Pk Ripple + Noise (20MHz)	280mVpp maximum
Module Efficiency	79% typical
Output overcurrent threshold (1,2)	3.8A typical
Soft output overvoltage set-point (2)	33V +/- 3%
Hard output overvoltage set-point (3)	36V +/- 3%
PFC output overvoltage set-point (2)	246V +/- 3%
Isolation Voltage, Input to Chassis (4)	1500Vac minimum
Isolation Voltage, Input to Output (5)	1500Vac minimum
Output ride-through / full load (6)	10mSec
MTBF (Aic, 50°C case)	571,000 Hours

### Notes:

1. 3.8A typical (4.5A max) with pulse retry current limiting & auto recovery into full load. Pulse is ~160mSec on and 2.3 seconds off in OCP mode
2. Auto recovery
3. Latching, requires AC power cycling to reset
4. 1500Vac, 60Hz for 60 seconds without arc or damage; 3.0mArms maximum leakage current (line-to-earth capacitors installed)
5. 1500Vac, 60Hz for 60 seconds without arc or damage; 3.0mArms maximum leakage current (line-to-earth capacitors installed)
6. 66uF internal hold-up capacitance, expandable by external capacitors
7. Requires external differential / common-mode filter installed on power lines for full compliance, see application section for details.

## TEMPERATURE CHARACTERISTICS

*AIRFLOW (LFM)	THERMAL IMPEDANCE ( $\theta_{s-a}$ ) (no external heatsink)
0 LFM	3.4 °C/W
250 LFM	1.0 °C/W
500 LFM	0.6 °C/W

\* Air velocity measured using a digital anemometer positioned within an airflow duct 3" X 3" above top of module

# PFC100W-28VPN-PBF

(115Vac, 47- 800Hz Input)













100W, 28V/ 3.6A Single Output,

Airborne PFC Power Module



## APPLICABLE SPECIFICATIONS

When configured properly within upper unit level LRU module will comply with following specifications. Many of these items have been verified at the module level and again at upper unit level in various airborne LRU configurations. In some instances individual specification compliance is tested and verified using module within same PFCXXW series and conforming by similarity.

	RTCA/DO-160G, section 4, altitude/ temperature (operating) to 15,000 feet, category A1 equipment
	RTCA/DO-160G, section 6, humidity (operating) category A
	RTCA/DO-160G, section 7, shock (operating) category S, curve C
	RTCA/DO-160G, section 8, vibration (operating) category S, curve C
	RTCA/DO-160G, section 15, magnetic effect, category B
	RTCA/DO-160G, section 16, power input requirements for 115V - AC input, category A(WF) equipment
	RTCA/DO-160G, section 17, voltage spike, category B equipment
	RTCA/DO-160G, section 18, conducted susceptibility, category Z equipment
	RTCA/DO-160G, section 19, induced signal susceptibility, category Z equipment
	RTCA/DO-160G, section 20, conducted and radiated susceptibility, category T equipment
	RTCA/DO-160G, section 21, conducted and radiated emissions, category M equipment
	Operating temperature: -40°C to +70°C, forced air and/ or external heatsinking may be required
	Storage temperature: -55°C to +100°C

# PFC100W-28VPN-PBF

(115Vac, 47- 800Hz Input)

100W, 28V/ 3.6A Single Output,  
Airborne PFC Power Module



## BLOCK DIAGRAM

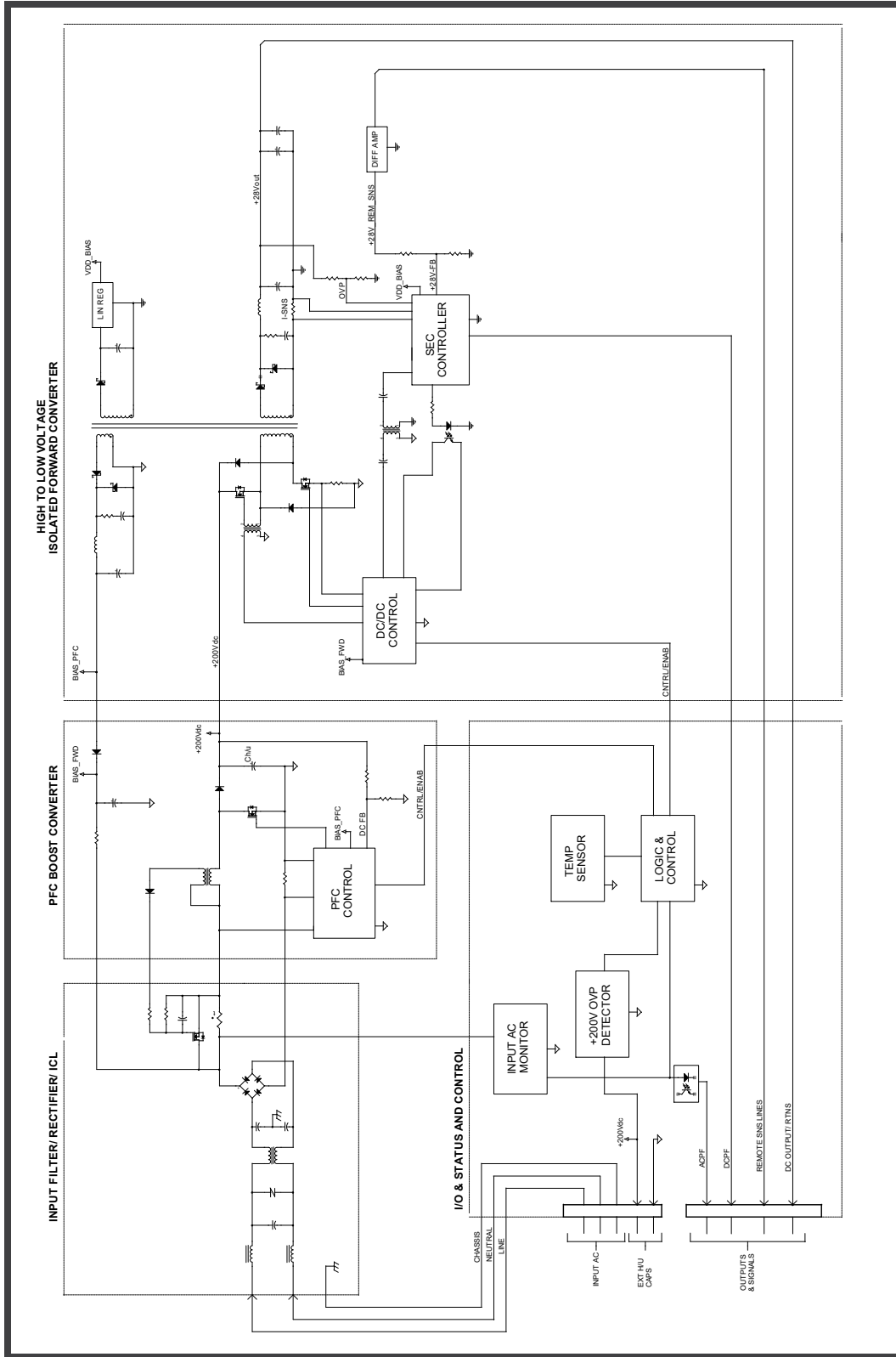

# PFC100W-28VPN-PBF

(115Vac, 47- 800Hz Input)

100W, 28V/ 3.6A Single Output,

Airborne PFC Power Module



## MECHANICAL DIAGRAM

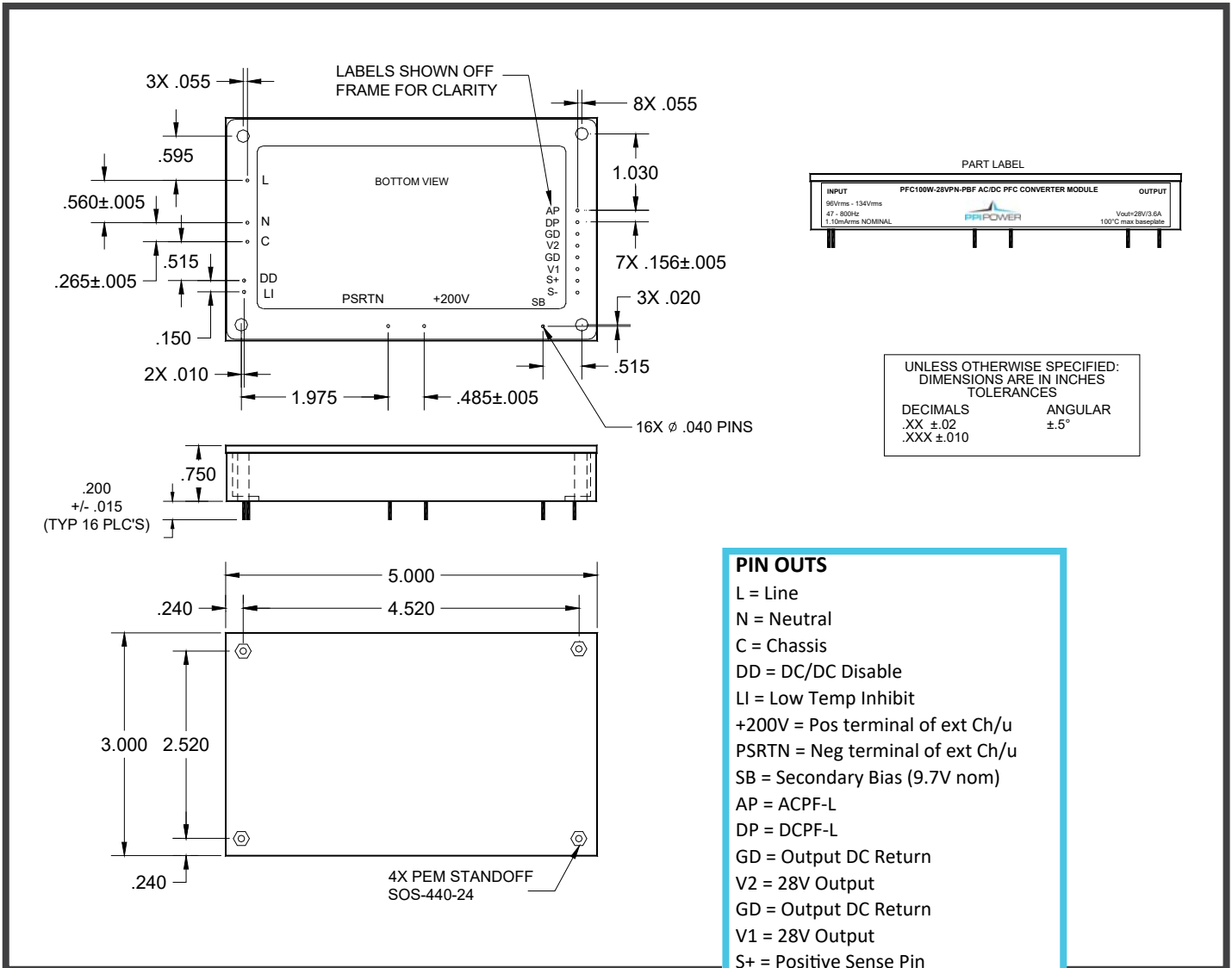

### \* BASEPLATE FLATNESS

Maximum warpage not to exceed  
0.04" per 5" unit length.

A DETAILED OUTLINE DRAWING CAN BE FURNISHED UPON REQUEST

# PFC100W-28VPN-PBF

(115Vac, 47- 800Hz Input)

100W, 28V/ 3.6A Single Output,

Airborne PFC Power Module



## ELECTRICAL SPECIFICATIONS

Unless otherwise specified the following test conditions apply: Ta = 25°C, constant active load applied to the 28V output, Ch/u (external) = 220uF, Vin = 115Vrms, 360Hz – 800Hz, <1.25% sinusoid.

## INPUT CHARACTERISTICS

PARAMETER	PFC100W-28VPN-PBF	REMARKS	NOTES
INPUT VOLTAGE RANGE	96 – 134Vrms	Complies with normal / abnormal input voltages per DO-160F, sect. 16.	2
MUST START VOLTAGE	96Vrms minimum	Module will start and remained enabled for input voltage in the range of 96Vrms < Vin < 134Vrms.	2
MUST INHIBIT VOLTAGE	89Vrms maximum	Module output will inhibit following ~800mSec turn-off delay upon detection of input undervoltage ≤89Vrms. 28V output to disable monotonically and remain disabled as long as input voltage remains ≤89Vrms.	2
INPUT FREQUENCY RANGE	47 – 800Hz	Reduced distortion performance below 360Hz.	2
EFFICIENCY	78% minimum full load 74% minimum half load	50% - 100% output load (50W-100W). 80% typical full load efficiency. See efficiency curve.	2
INPUT POWER LIMIT	170W +/- 6W	Average input power limit range.	2
LEAKAGE CURRENT	< 2mArms	AC Line/ Neutral to Chassis at 115Vrms/ 400Hz.	1
INRUSH CURRENT	< 7Apk	Cold or warm start; 5Apk typical.	2
Athd INPUT CURRENT	< 5.5%	50% - 100% output load (50W-100W).	2
INDIVIDUAL HARMONICS AC CLEAN	EVEN: <1% If / n (n < 10) EVEN: <0.1%If (n ≥ 10) ODD: <30% If / n ODD TRIPLENS:<15% If /n	If = Fundamental current Vthd < 1.25% n = order of harmonic (1 - 40) 50% - 100% output load (50W-100W). Harmonics < 10mA disregarded.	1
INDIVIDUAL HARMONICS DISTORTED INPUT	EVEN: <1% If / n + 1.25Vn (n < 10) EVEN: <0.1%If + 1.25Vn (n ≥ 10) ODD: <30% If / n + 1.25Vn ODD TRIPLENS:<15% If /n+1.25Vn	If = Fundamental current Vthd > 10% (clipped method), n = order of harmonic (1 - 40) Vn = corr input voltage harmonic. 50% - 100% output load (50W-100W). Harmonics < 10mA disregarded.	1

# PFC100W-28VPN-PBF

(115Vac, 47- 800Hz Input)

100W, 28V/ 3.6A Single Output,

Airborne PFC Power Module



## INPUT CHARACTERISTICS—CONTINUED

PARAMETER	PFC100W-28VPN-PBF	REMARKS	NOTES
QUIESCENT POWER	6W typical	No load applied to output.	1
POWER FACTOR	0.98 min	Pout > 50W at 400Hz, Pout > 55W at 800Hz.	2
CREST FACTOR (CURRENT)	1.314 – 1.514	Ratio of peak / RMS.	1
START-UP TIME	< 750mSec	Output within proper regulation.	2
CONDUCTED EMISSIONS	RTCA/DO-160G	Section 21, category M.	1, 4
STORAGE TEMPERATURE RANGE	-55°C to +100°C	Non-operational.	1
OPERATING TEMPERATURE RANGE	-40°C to +70°C	Observe maximum baseplate temperature of +100°C. Module will take several seconds to start when starting below 0°C ambient.	1
LOW TEMPERATURE INHIBIT	0°C ± 3°C	Module's 28V output is inhibited at or below 0°C. Auto restart occurs when temperature rises above 0°C. The low temperature inhibit set point can be adjusted lower using one external low power resistor installed between LI pin and PSRTN pin, see application section for details.	1
OVERTEMPERATURE SHUTDOWN	100°C ± 4°C	Module's 28V output is inhibited at or above 100°C. Auto restart occurs at ~ 80°C baseplate temperature.	1
DC/DC CONV DISABLE-L	0.5V Maximum	Module's DC/DC converter can be disabled by applying a logic low to DD pin with respect to PSRTN pin. Delay time from application of logic low to converter disabling is <1mSec. Float DD pin to enable DC/DC converter.	1

# PFC100W-28VPN-PBF

(115Vac, 47- 800Hz Input)

100W, 28V/ 3.6A Single Output,

Airborne PFC Power Module



## OUTPUT CHARACTERISTICS

PARAMETER	PFC100W-28VPN-PBF	REMARKS	NOTES
RATED OUTPUT POWER	100W continuous	Observe maximum allowable baseplate temperature; see application section for details.	2
OUTPUT VOLTAGE	28Vdc +/-2%	No load to full load (100W).	2, 5
REMOTE SENSE LINES	Maximum 700mV drop in output lines combined	Maximum allowable margin-up is 700mV for a ~28.9Vdc output. If not used at point-of-load, sense lines should be looped back at module output pins. See application section for details. No damage will occur if sense lines are not connected.	1
OUTPUT OVERCURRENT THRESHOLD	3.8A typical, 4.5A maximum	Output current and voltage will foldback with pulse retry current limiting circuit. Pulse retry duty cycle is ~160mSec on and ~2.3 seconds off in OCP mode, cyclic mode as long as fault persists. No damage will occur to module during indefinite output short circuit conditions. Output will auto recovery into full rated load when fault clears.	2
TEMPERATURE STABILITY COEFFICIENT	0.05% / °C	Output voltage variation with temperature (500uV / °C).	1
OUTPUT RIPPLE + NOISE	280mVpp maximum	20MHz bandwidth. 180mVpp typical. Can be reduced with external capacitors, see application notes.	2
LINE REGULATION	<0.5%	Output deviation for +/- 20% step change in input voltage.	1
LOAD REGULATION	Output remains in regulation	50% step change in output load. Full load to half load or half load to full load. 10uSec rise/fall time.	1
MINIMUM LOAD	0A	No minimum load is necessary.	2
HOLD-UP TIME	5mSec nominal	No external hold-up capacitor attached. Requires external 250V rated capacitors to extend hold-up time. May be affected by warm start delay, see application section for details.	1
MAXIMUM EXTERNAL HOLD-UP CAPACITANCE	2800uF	Specified in order to not overstress the internal inrush current limiting circuit	1
ISOLATION VOLTAGE INPUT TO CHASSIS	1500Vac, 60Hz	No arcing or damage for 60-second test duration (3.0mArms max leakage).	2, 6
ISOLATION VOLTAGE INPUT TO OUTPUT	1500Vac, 60Hz	No arcing or damage for 60-second test duration (3.0mArms max leakage).	2, 7
INSULATION RESISTANCE OUTPUT TO CHASSIS	500Vdc	100M-ohms minimum (after 5 secs minimum).	2
INSULATION RESISTANCE INPUT TO OUTPUT	500Vdc	100M-ohms minimum (after 5 secs minimum).	1



# PFC100W-28VPN-PBF

(115Vac, 47- 800Hz Input)

100W, 28V/ 3.6A Single Output,

Airborne PFC Power Module



## OUTPUT CHARACTERISTICS—CONTINUED

PARAMETER	PFC100W-28VPN-PBF	REMARKS	NOTES
DCPWRFAIL-L (DP)	Transitions to TTL low (0.5Vmax) when 28Vdc output is detected at 7.5% or more below normal set point	TTL level, 3mA max sink current. Time to activation on a fault is 1mSec typical, 2.5mSec maximum.	2
ACPWRFAIL-L (AP)	Transitions to TTL low (0.5Vmax) upon detection of invalid input AC ( $\leq 89V_{rms}$ from 0% - 100% load)	TTL level, 16mA max sink current, 5mSec maximum delay time to activate on loss of input AC.	2
PFC 200Vdc OUTPUT	200Vdc $\pm$ 3%	10W $\leq$ Pout < 100W.	2, 3
MINIMUM DC/DC CONVERTER OPERATING VOLTAGE	100Vdc	Minimum amplitude for PFC output that will guarantee proper output regulation for the 28V output.	1
OUTPUT OVERVOLTAGE PROTECTION "SOFT"	33V $\pm$ 3%	Pulse by pulse protection (inner loop), auto-restart.	1
OUTPUT OVERVOLTAGE PROTECTION "HARD"	36V $\pm$ 3%	Module will be latched off if output is detected at or above this level. Requires recycling of input AC to reset module.	1
OUTPUT OVERVOLTAGE PROTECTION (PFC 200Vdc OUTPUT)	246V $\pm$ 3%	PFC output is clamped to this level if control loop regulation is lost, auto-recovery.	1
9.7V BIAS OUTPUT	9.7V +/- 10%	Secondary referenced low current bias voltage available for general purpose use. This pin is labeled SB and can provide up to 25mA and is internally protected against output short circuit conditions. SB is only available when DC/DC converter is enabled (no fault condition) and 28V output is present.	1

### Notes:

1. Ensured by design, not 100% tested in production.
2. 100% tested for specification compliance in production.
3. 200Vdc PFC output voltage tolerance is +/-5% for Pout < 10W.
4. Requires external differential / common-mode filter installed on power lines for full compliance, see application section for details.
5. With remote sense line connected at output pins (looped back).
6. When performing input to chassis isolation voltage testing at the module level it is recommended to tie the primary referenced terminals: Line, Neutral, +200V and PSRTN together and hi-pot all of these with respect to chassis ground.
7. When performing input to output isolation voltage testing at the module level it is recommended to tie the primary referenced terminals: Line, Neutral, +200V and PSRTN together and hi-pot all of these with respect to all of the secondary referenced terminals which are also tied together (this includes AP, DP, GD, VO, S+ and S-).

# PFC100W-28VPN-PBF

(115Vac, 47- 800Hz Input)

100W, 28V/ 3.6A Single Output,  
Airborne PFC Power Module



## EFFICIENCY CURVE

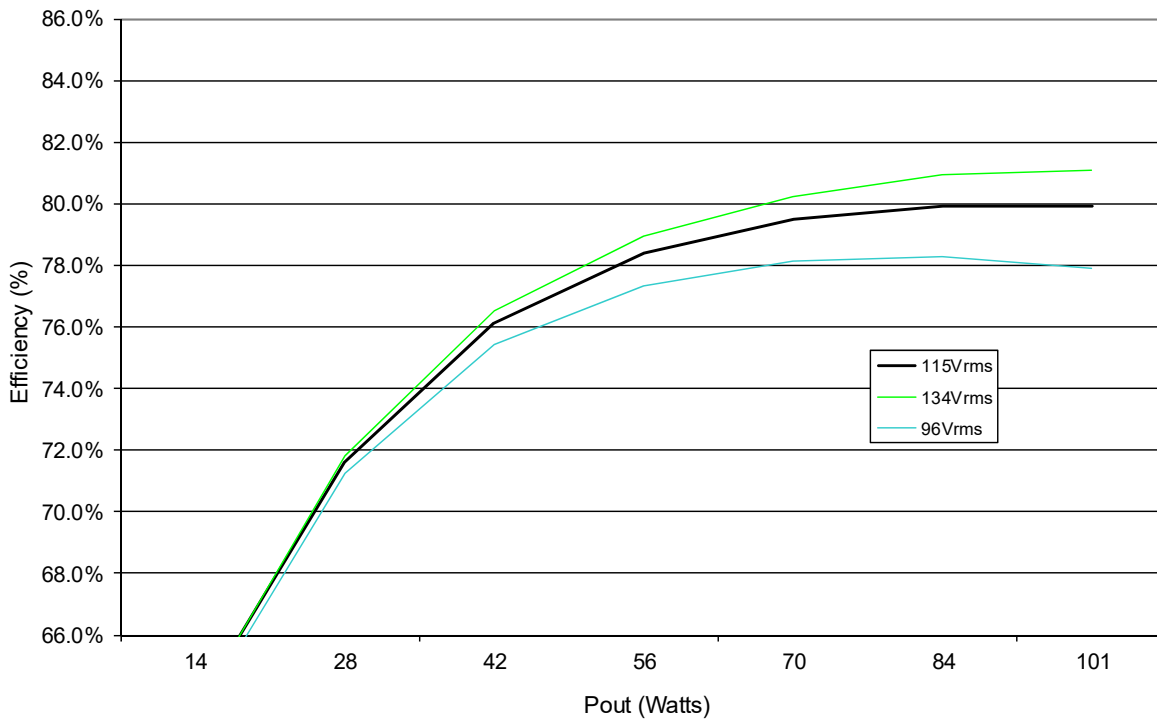

# PFC100W-28VPN-PBF

(115Vac, 47- 800Hz Input)

100W, 28V/ 3.6A Single Output,

Airborne PFC Power Module



## APPLICATIONS INFORMATION

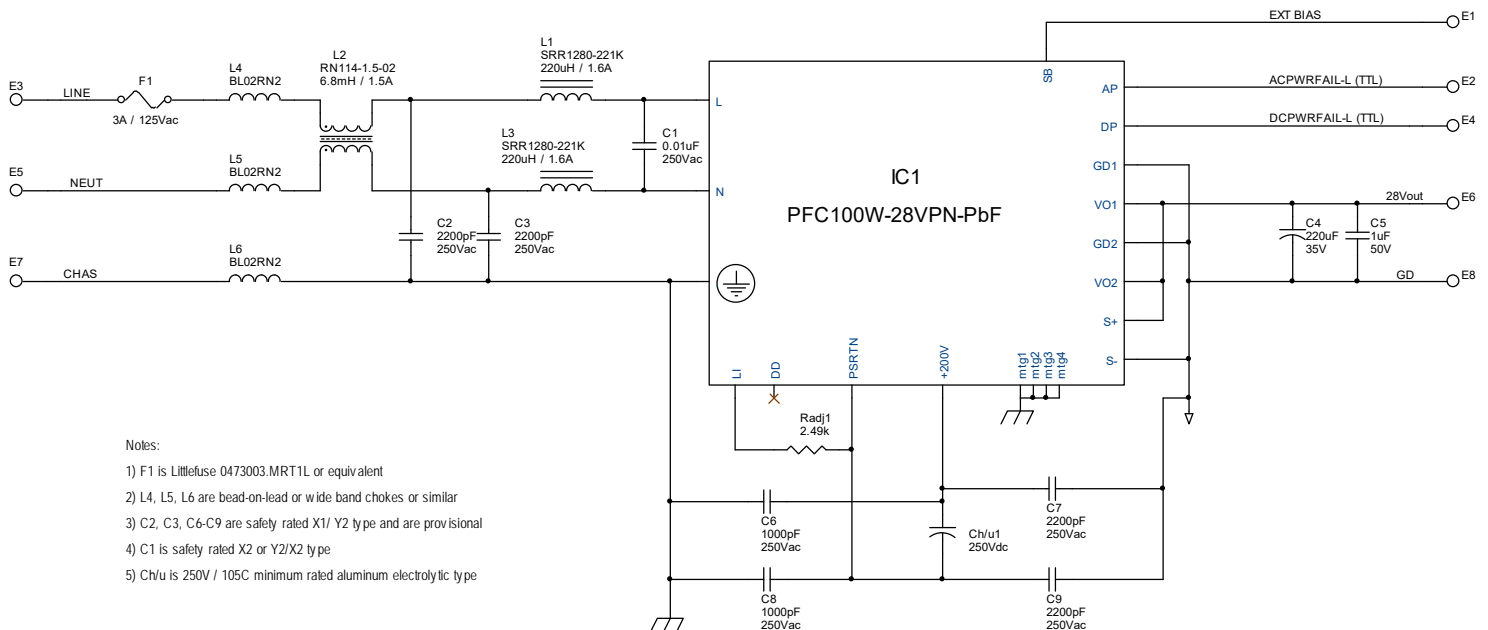

### Notes:

- 1) F1 is Littelfuse 0473003.MRT1L or equivalent
- 2) L4, L5, L6 are bead-on-lead or wide band chokes or similar
- 3) C2, C3, C6-C9 are safety rated X1/ Y2 type and are provisional
- 4) C1 is safety rated X2 or Y2/X2 type
- 5) Ch/u is 250V / 105C minimum rated aluminum electrolytic type

Typical Application Circuit

# PFC100W-28VPN-PBF

(115Vac, 47- 800Hz Input)

100W, 28V/ 3.6A Single Output,

Airborne PFC Power Module



## HOLD-UP TIME

The PFC100W series module provides two interconnecting pins in order to extend hold-up time with external capacitors. In order to extend module hold-up time, polarized 250V (minimum) electrolytic capacitors must be connected externally between the module's +200Vpin and PSRTN pin. Required external capacitance can be determined using the following formula:

$$E = P * (t + t_{\text{restart}}) = (0.89) * \{ \frac{1}{2} C_{h/u} (\text{total}) (V_i^2 - V_f^2) \}$$

Where,

P = output power (Watts)

t = desired hold-up time (Seconds)

t<sub>restart</sub> = warm start delay of approximately 25mSec upon reapplication of input AC

C<sub>h/u (total)</sub> = total hold-up capacitance (Farads), includes internal 53uF (minimum) and external capacitance

C<sub>h/u (ext)</sub> = external hold-up capacitance (Farads)

0.89 factor constitutes internal DC/DC converter efficiency

V<sub>i</sub> = Minimum PFC voltage of 194Vdc (200Vdc - 3%)

V<sub>f</sub> = Minimum internal DC/DC converter operating voltage of 100 Volts

$$E = P * (t + t_{\text{restart}}) = (0.89) * \{ \frac{1}{2} C_{h/u} (V_i^2 - V_f^2) \}$$

In order to hold up 100W external power for 200mSec requires:

$$C_{h/u} (\text{total}) = \{ (100W) (200mSec + 25mSec) \} \div \{ (1/2) (0.89) (194V^2 - 100V^2) \} = 1830uF$$

$$C_{h/u} (\text{ext}) = C_{h/u} (\text{total}) - 53uF = 1830uF - 53uF = 1780uF (\text{minimum})$$

Use of 105°C, 250Vdc, 20% tolerance snap-mount aluminum electrolytic capacitors is recommended. For the example above, a total nominal capacitance of 2220uF would be necessary to assure the required capacitance of 1780uF was achieved. Warm start delay occurs for AC power interrupts greater than 25mSec as a result of combination of time to reactivate PFC control circuitry, reinitiation of PFC soft-start cycle and reaching module power limit.

## PLACEMENT, FLATNESS AND MOUNTING

The PFC100W series modules may be flush mounted and soldered to a PCB. The baseplate (topside) may be mounted to a flat surface for heatsinking or to a stand-alone heatsink. If mounting the baseplate to a flat surface a thermal interface pad is recommended as some warpage of the module's aluminum baseplate may exist. Warpage of the baseplate surface (including bow and twist) occurs in the manufacturing of the internal thermal clad circuit board and is a result of high temperatures required during the lamination process as well as during the panel cutting process. Baseplate warpage is limited to 0.04" per 5" unit length. Temperature activated thermally conductive interface pads, such as Chomeric's T725 series, are suitable interface pads for this application.

The PFC100W module contains 4 corner threaded #4 mounting holes (see mechanical diagram for details). The standard mounting hole configuration is partially threaded; threaded approximately 0.44" through from the baseplate side of the module.

# PFC100W-28VPN-PBF

(115Vac, 47- 800Hz Input)

100W, 28V/ 3.6A Single Output,

Airborne PFC Power Module



## SOLDERING INFORMATION

In order to minimize mechanical force exerted on the module pins, the module should be mechanically fastened to the printed circuit board prior to soldering each of the I/O pins. The pins are soldered internally to the module's horizontal through-hole circuit board using a high temperature solder that allows for application of high heat for long time durations when soldering the module to an external circuit board without concern for re-flow of the internal solder joints. The allowable heat application versus time duration curve is shown below and should be adhered to in order to prevent re-flow of the module pins internal solder joints.

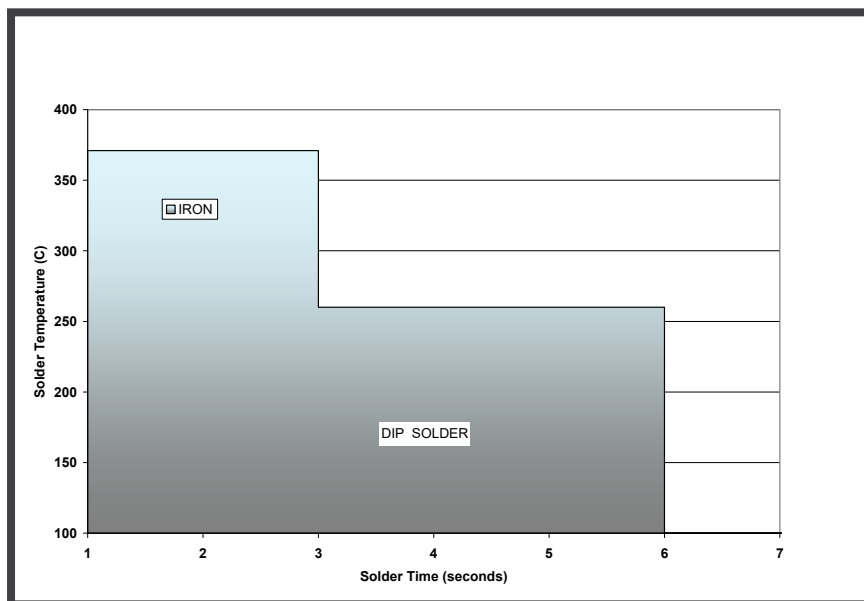

## ROUTING CONSIDERATIONS

Assure there is at least 4.2mm between primary referenced and secondary referenced signals. Secondary referenced signals include AP, DP, SB, S+, S-, V1, V2 and GD. Avoid routing secondary referenced signals directly beneath module on component layer.

## REMOTE SENSE LINES

Remote sense capability is provided in order to “margin-up” the 28V output to overcome small system level voltage drops in traces and connectors. If using the remote sense lines, the maximum allowable system level voltage drop (or combined differential voltage between V1, V2 and +SNS and GD and -SNS) is 700mV. Exceeding this amplitude may force the module's overvoltage protection circuit to activate. If not using the remote sense line feature at a remote point-of-load, each sense line should be terminated at the output pins of the module (+SNS to V1, V2 and -SNS to GD). Remote sense lines should be connected directly to the +28V and GD power forms prior to any additional inductive filter elements that may be included.

# PFC100W-28VPN-PBF

(115Vac, 47- 800Hz Input)

100W, 28V/ 3.6A Single Output,

Airborne PFC Power Module



## CAPACITIVE LOADING AND PROPER POWER-UP CONSIDERATIONS

Avoid applying full (3.6A) load current to the module's output prior to allowing the output to reach at least 12Vdc to avoid module latch-up when starting. Module latch-up can occur under certain power-up modes (e.g., low line) if the module enters internal power-limit prior to its internal bias voltages reaching minimum operating levels. If implementing active loading on the modules output (constant current sink), assure that the turn-on voltage of the active load instrument is set to at least 12Vdc. If implementing external bulk capacitors on the module's 28V output, assure proper power-up under all input line and output load conditions.

## EMI CONSIDERATIONS

Use of a chassis ground plane beneath module on first internal circuit board layer (beneath component layer) of PCB is recommended. Assure that sufficient isolation distance exists between chassis plane and each of the modules input and output pins such that there is at least 4.2mm between primary referenced and secondary referenced signals. Although the PFC100W series modules contain internal common-mode and differential mode input filtering the use of an external inductive based line filter is required for EMI compliance. See application circuit for suggested filter arrangement. If there are exceedances after preliminary scans are performed it may be necessary for two common mode chokes in cascade be installed on the primary (input) side as well as an additional common mode choke on the secondary side (28Vdc output) side. Reduce or eliminate line-to-line capacitance (C1) for applications operating at low power levels (<50W output) as it may have an adverse effect on input current harmonic distortion at higher line frequencies (e.g., 800Hz).

If external hold-up capacitors are more than 3 inches away from module, 1000pF decoupling capacitors (line-to-earth rated) should be installed between +200V signal and chassis ground and PSRTN signal and chassis ground in close proximity to respective module terminals.

In order to reduce differential switching noise on the DC output voltage, adding a parallel combination of low ESR Aluminum Polymer and MLCC ceramic capacitors from V1, V2 to GD is recommended. Recommended low ESR electrolytic capacitors include Nichicon PCR1V221MCL1GS and AVX 1206/1210 series flexible termination type MLCC capacitors for the 1uF.

# PFC100W-28VPN-PBF

(115Vac, 47- 800Hz Input)

100W, 28V/ 3.6A Single Output,

Airborne PFC Power Module



## THERMAL CONSIDERATIONS

There is no derating required for module output power up to the module baseplate temperature of 100°C. Beyond this temperature the module will shutdown. In order to assure the baseplate temperature remains below 100°C additional heatsinking or forced airflow may be required. In order to estimate baseplate temperature and whether external heatsinking or airflow is necessary, apply the following formulas:

$$T_{\text{baseplate}} = T_{\text{ambient}} + (P_{\text{diss}})(\Theta_{\text{s-a}})$$

Where:

$T_{\text{baseplate}}$  = module baseplate temperature in °C,

$T_{\text{ambient}}$  = ambient air temperature in °C,

$\Theta_{\text{s-a}}$  = thermal resistance from module baseplate to ambient air in °C/W without external heatsink,

eff = module efficiency from appropriate curve,

$P_{\text{diss}} = \{(P_{\text{out}} \div \text{eff}) - P_{\text{out}}\}$  in watts

As an example,

Assume a desired output power of 100W at nominal line operation (115Vrms) with a maximum ambient temperature of 70°C. The following formula would apply:

$$T_{\text{baseplate}} = 70^{\circ}\text{C} + \{[(100\text{W} / 0.80) - 100\text{W}]\} (3.4^{\circ}\text{C/W}) = 155.0^{\circ}\text{C}$$

Therefore either an external heatsink would be required or forced airflow such that  $\Theta_{\text{s-a}}$  was reduced to:

$$\Theta_{\text{s-a}} < \{(T_{\text{baseplate}} - T_{\text{ambient}}) \div P_{\text{diss}}\}$$

$$\Theta_{\text{s-a}} < \{100^{\circ}\text{C} - 70^{\circ}\text{C}\} \div \{(100\text{W} / 0.80) - 100\text{W}\} < 1.20^{\circ}\text{C/W}$$