

PFC50W-28V

(115Vac, 47- 800Hz Input)

50W, 28V/1.8A Single Output,

Airborne PFC Power Module



Targeting low power avionics' applications, the **PFC50W-28V** module provides an isolated 28Vdc output with an integral PFC input converter stage. It meets the most stringent airborne requirements including those for variable frequency 115Vac generator systems over the wide frequency range of 360-800Hz and RTCA/DO-160E category M emissions.

Utilizing thermal-clad circuit board technology and low profile planar magnetics, thermal gradients between heat dissipating components and the module baseplate are minimized while maintaining a low 0.75" profile.

The **PFC50W-28V** is capable of providing uninterrupted ride-through at full output load during momentary input AC brown-out conditions for up to 10mSec. Hold-up time is readily expanded by connecting external electrolytic capacitors to the PFC output pins provided. Standard protection features are built-in in to assure years of fault-tolerant and reliable operation in the harshest environments.

Weighing less than 18 ounces, the **PFC50W-28V** is housed in a silicon-based encapsulated enclosure with outer dimensions of 5.0" x 3.0" x 0.75". Four corner mounting holes are included to facilitate system mounting. The **PFC50W-28V** is intended for low-profile PCB mount applications where the topline baseplate can be flush mounted to LRU chassis sidewalls or a stand-alone heatsink.



FEATURES

	Meets both RTCA/DO-160E, section 16, and Airbus ABD0100.1.8 issue D for power factor and input current harmonic distortion levels over the wide frequency operating range (360Hz – 800Hz) at ½ to full rated load
	Wide input range: 90Vrms – 134Vrms, 47 – 800Hz
	Complies with RTCA/DO-160E for conducted emissions, susceptibility and power input (section 16)
	Active inrush current limiting: 5Apk typical, 7Apk maximum
	Size: 5.0" x 3.0" x 0.75", Weight: less than 18 ounces
	Tightly regulated isolated output: 28V/ 1.8A
	Overcurrent protection with foldback current limiting
	Output overvoltage protection
	PFC output overvoltage protection with automatic restart (internal 200Vdc PFC output)
	Over-temperature shutdown with automatic restart (baseplate at or above 100°C)
	DC output valid status line (TTL)
	AC valid status line (TTL)
	MTBF (RIAC 217Plus, Aic, 50°C OPERATING TEMPERATURE, 65% DC, 2190 Cycles/ yr.) 667,000 HOURS

PFC50W-28V

(115Vac, 47- 800Hz Input)

50W, 28V/1.8A Single Output,

Airborne PFC Power Module



PERFORMANCE SUMMARY

PARAMETER	SPECIFICATIONS
Voltage regulation	+28Vdc +2,-1%
Rated output current	1.8A
Minimum load	50mA
Pk-Pk Ripple + Noise (20MHz)	280mVpp maximum
Module Efficiency	77% typical
Output overcurrent threshold (1)	2.1A typical
Output overvoltage set-point (2)	33V +/- 3%
PFC output overvoltage set-point (2)	246V +/- 3%
Isolation Voltage (3) (Input to Output & Input to Chassis)	1500Vac minimum
Output ride-through / full load (4)	10mSec
MTBF (Aic, 50°C case)	667,000 Hours

Notes:

1. 2.1A typical (2.25A maximum) with foldback current limiting and auto recovery into full load
2. Auto recovery
3. 1500Vac, 60Hz for 60 seconds without arc or damage; 3.0mA maximum leakage current (line-to-earth capacitors installed)
4. 44uF internal hold-up capacitance, expandable by external capacitors

TEMPERATURE CHARACTERISTICS

* AIRFLOW	THERMAL IMPEDANCE (θ_{s-a})
0 LFM	3.4 °C/W
250 LFM	1.0 °C/W
500 LFM	0.6 °C/W

* Air velocity measured using a digital anemometer positioned within an airflow duct 3" X 3" above top of module

PFC50W-28V

(115Vac, 47- 800Hz Input)

50W, 28V/1.8A Single Output,
Airborne PFC Power Module



BLOCK DIAGRAM

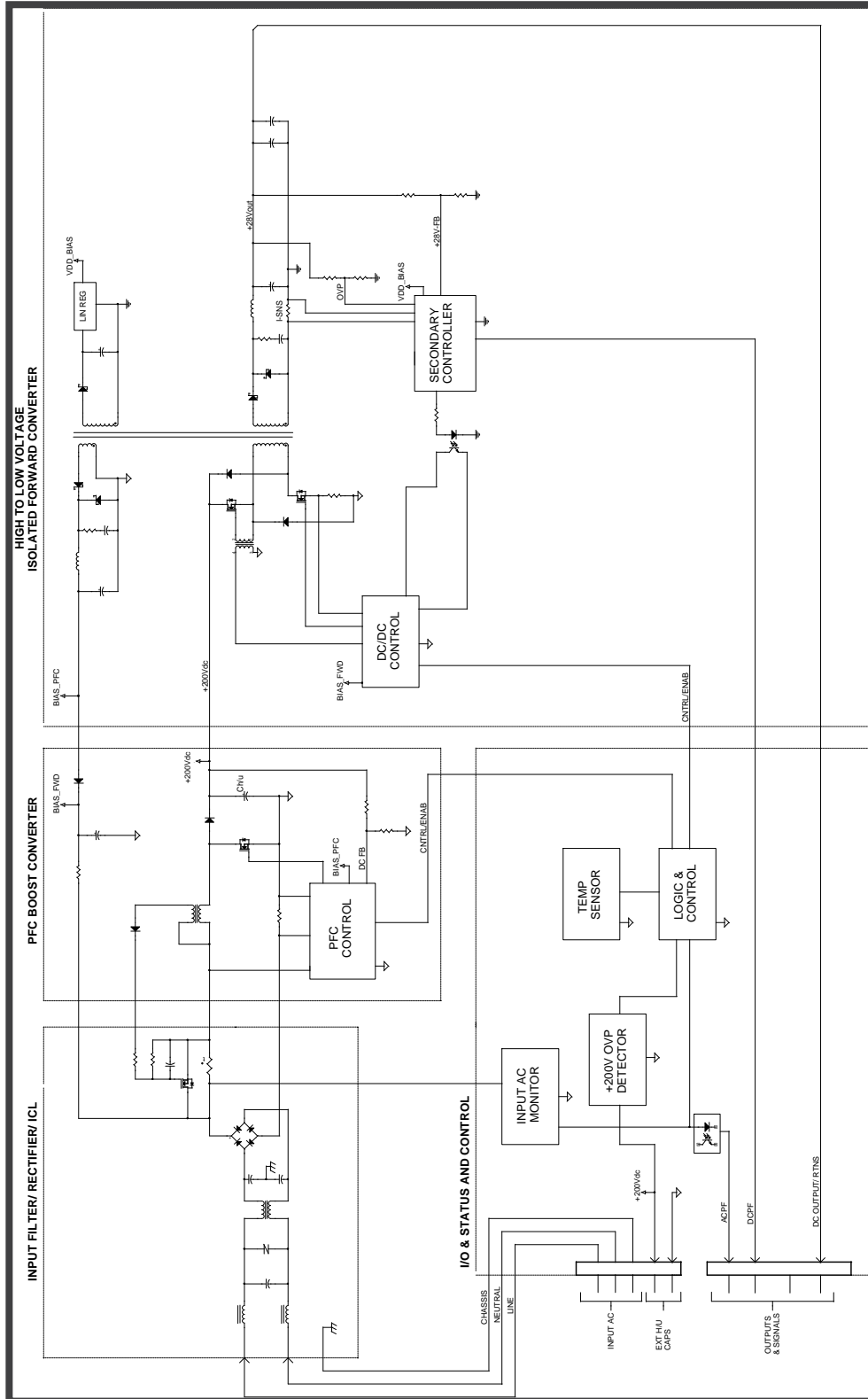

PFC50W-28V

(115Vac, 47- 800Hz Input)

50W, 28V/1.8A Single Output,

Airborne PFC Power Module



MECHANICAL DIAGRAM

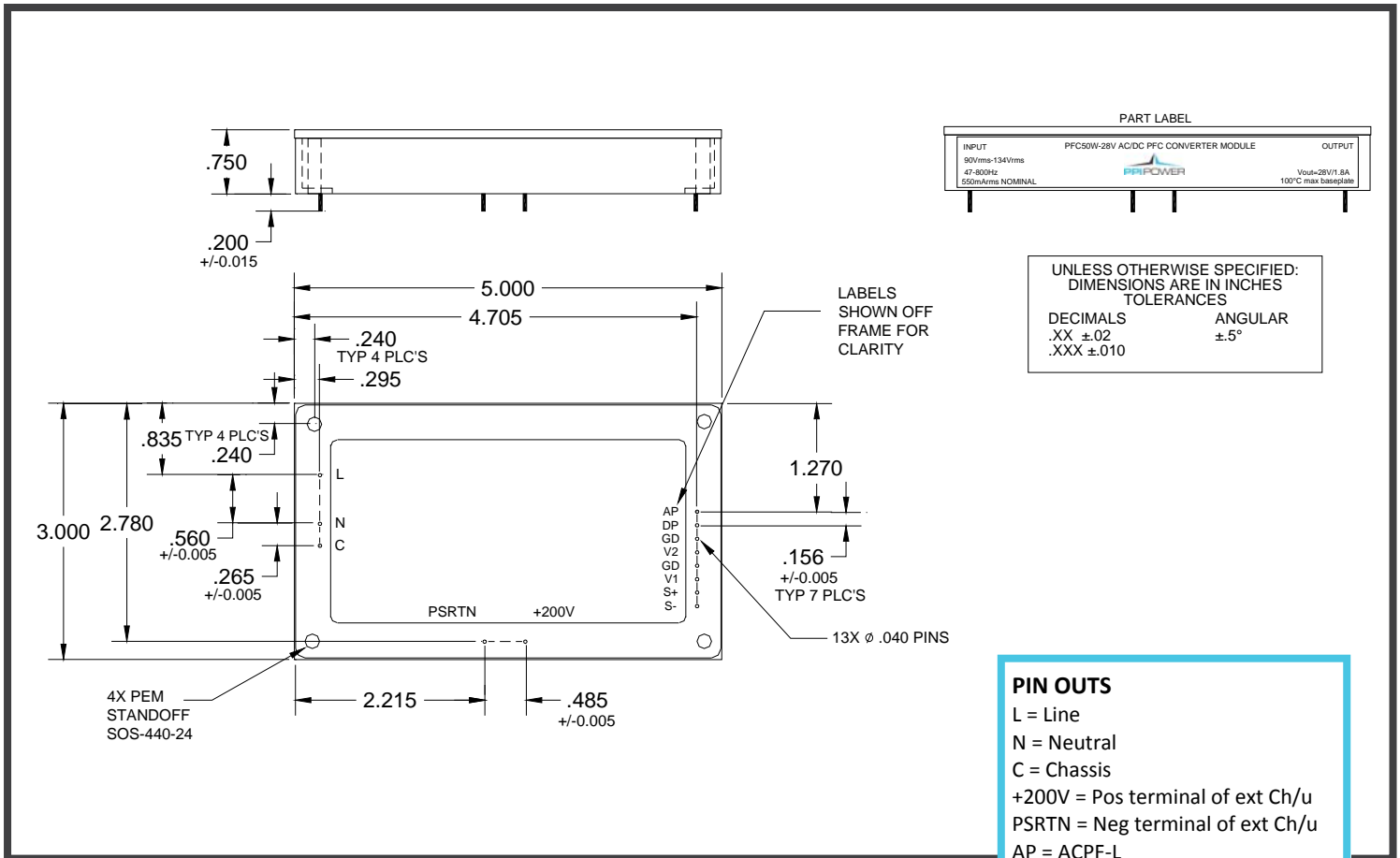

* BASEPLATE FLATNESS

Maximum warpage not to exceed
0.04" per 5" unit length.

A DETAILED OUTLINE DRAWING CAN BE FURNISHED UPON REQUEST

PFC50W-28V

(115Vac, 47- 800Hz Input)

50W, 28V/1.8A Single Output,

Airborne PFC Power Module



ELECTRICAL SPECIFICATIONS

Unless otherwise specified the following test conditions apply: $T_a = 25^\circ\text{C}$, constant active load applied to the 28V output, C_h/u (external) = 220uF, $V_{in} = 115\text{Vrms}$, 360Hz – 800Hz, <1.25% sinusoid.

INPUT CHARACTERISTICS

PARAMETER	PFC50W-28V	REMARKS	NOTES
INPUT VOLTAGE RANGE	90 – 134Vrms	Complies with normal / abnormal input voltages per DO-160E, sect. 16.	2
MUST START VOLTAGE	90Vrms minimum	Module will start and remained enabled for input voltage in the range of 90Vrms < V_{in} < 134Vrms.	2
INPUT FREQUENCY RANGE	47 – 800Hz	Reduced distortion performance below 360Hz.	2
EFFICIENCY	73% minimum	50% to 100% output loading (25.5W to 51W); 77% typical full load efficiency.	2
LEAKAGE CURRENT	< 2mA _{rms}	AC Line / Neutral to Chassis at 115Vrms / 400Hz.	1
INRUSH CURRENT	< 7A _{pk}	Cold or warm start; 5A _{pk} typical.	2
TOTAL HARMONIC DISTORTION (INPUT CURRENT)	< 5.5%	50% to 100% output load (25.5W to 51W).	2
INDIVIDUAL HARMONICS AC CLEAN	EVEN: <1% I_f / n ($n < 10$) EVEN: <0.1% I_f ($n \geq 10$) ODD: <30% I_f / n ODD TRIPLES:<15% I_f / n	I_f = Fundamental current $V_{thd} < 1.25\%$, n = order of harmonic (1 - 40) 50% to 100% output load (25.5W to 51W).	1
INDIVIDUAL HARMONICS DISTORTED INPUT	EVEN: <1% $I_f / n + 1.25V_n$ ($n < 10$) EVEN: <0.1% $I_f + 1.25V_n$ ($n \geq 10$) ODD: <30% $I_f / n + 1.25V_n$ ODD TRIPLES:<15% $I_f / n + 1.25V_n$	I_f = Fundamental current $V_{thd} > 10\%$ (clipped method), n = order of harmonic (1 - 40) V_n = corresponding input voltage harmonic. 50% to 100% output load.	1
QUIESCENT POWER	7.7W	1.4W load applied to output.	1
POWER FACTOR	0.90 min	$P_{out} > 20W$.	2
CREST FACTOR (CURRENT)	1.314 – 1.514	Ratio of peak / RMS.	1

PFC50W-28V

(115Vac, 47- 800Hz Input)

50W, 28V/1.8A Single Output,

Airborne PFC Power Module



INPUT CHARACTERISTICS—CONTINUED

PARAMETER	PFC50W-28V	REMARKS	NOTES
START-UP TIME	< 750mSec	Output within proper regulation.	2
CONDUCTED EMISSIONS	RTCA/DO-160E	Section 21, category M.	1
STORAGE TEMPERATURE RANGE	-55°C to +100°C	Non-operational.	1
OPERATING TEMPERATURE RANGE	-15°C to +70°C	Observe maximum baseplate temperature of +100°C.	1
LOW TEMPERATURE INHIBIT	-22°C ± 3°C	Module's 28V output is inhibited at or below -22°C. Auto restart occurs when temperature rises above -22°C.	1
OVERTEMPERATURE SHUTDOWN	100°C ± 4°C	Module's 28V output is inhibited at or above 100°C. Auto restart occurs at ~ 80°C baseplate temperature.	1

PFC50W-28V

(115Vac, 47- 800Hz Input)

50W, 28V/1.8A Single Output,

Airborne PFC Power Module



OUTPUT CHARACTERISTICS

PARAMETER	PFC50W-28V	REMARKS	NOTES
RATED OUTPUT POWER	51W minimum	Continuous. Observe maximum allowable baseplate temperature; see application information for details.	2
OUTPUT VOLTAGE	28Vdc +2,-1%	1.4W to full load (51W).	2
OUTPUT OVERCURRENT THRESHOLD	2.1A typical, 2.25A maximum	Output voltage will foldback, auto-recovery. No damage will occur to module during indefinite output short circuit conditions.	2
TEMPERATURE STABILITY COEFFICIENT	0.05% / °C	Output voltage variation with temperature (500uV / °C).	1
OUTPUT RIPPLE + NOISE	280mVpp maximum	20MHz bandwidth. 100mVpp typical. Can be reduced with external capacitors, see application notes.	2
LINE REGULATION	<0.5%	Output deviation for +/- 20% step change in input voltage.	1
LOAD REGULATION	Output remains in regulation	50% step change in output load. Full load to half load or half load to full load. 10uSec rise/fall time.	1
MINIMUM LOAD	1.4W (50mA)	Module requires minimum load in order to regulate output properly. No damage or overvoltage will occur if minimum load is not provided.	2
HOLD-UP TIME	10mSec nominal	No external hold-up capacitor attached. Requires external 250V rated capacitors to extend hold-up time.	1
HOLD-UP TIME	50mSec minimum	Full 51W output load, external 220uF hold-up capacitor attached.	2
MAXIMUM EXTERNAL HOLD-UP CAPACITANCE	1500uF	Specified in order to not overstress the internal inrush current limiting circuit	1
ISOLATION VOLTAGE INPUT TO CHASSIS	1500Vac, 60Hz	No arcing or damage for 60-second test duration (3.0mArms max leakage).	2,4
ISOLATION VOLTAGE INPUT TO OUTPUT	1500Vac, 60Hz	No arcing or damage for 60-second test duration (3.0mArms max leakage).	2,5
ISOLATION VOLTAGE OUTPUT TO CHASSIS	250Vdc	No arcing or damage for 60-second test duration (100Mohm min).	1

PFC50W-28V

(115Vac, 47- 800Hz Input)

50W, 28V/1.8A Single Output,

Airborne PFC Power Module



OUTPUT CHARACTERISTICS—CONTINUED

PARAMETER	PFC50W-28V	REMARKS	NOTES
DCPWRFAIL-L (DP)	Transitions to TTL low (0.5Vmax) when 28Vdc output is detected outside of proper regulation window	TTL level, 3mA max sink current. Time to activation on a fault is 1mSec typical, 2.5mSec maximum.	2
ACPWRFAIL-L (AP)	Transitions to TTL low (0.5Vmax) upon detection of loss of input AC	TTL level, 3mA max sink current, 30mSec maximum delay time to activate on loss of input AC.	2
PFC 200Vdc OUTPUT	200Vdc \pm 3%	10W \leq Pout < 51W.	2, 3
MINIMUM DC/DC CONVERTER OPERATING VOLTAGE	110Vdc	Minimum amplitude for PFC output that will guarantee proper output regulation for the 28V output.	1
OUTPUT OVERVOLTAGE PROTECTION	33V \pm 3%	Pulse by pulse protection (inner loop), auto-restart.	1
OUTPUT OVERVOLTAGE PROTECTION (PFC 200Vdc OUTPUT)	246V \pm 3%	PFC output is clamped to this level if control loop regulation is lost, auto-recovery.	1
OUTPUT VOLTAGE ADJUSTMENT	None		--

Notes:

1. Ensured by design, not 100% tested in production.
2. 100% tested for specification compliance in production.
3. 200Vdc PFC output voltage tolerance is +/-5% for Pout < 10W.
4. When performing input to chassis isolation voltage testing at the module level it is recommended to tie the primary referenced terminals: Line, Neutral, LI, DD, +200V and PSRTN together and hi-pot all of these with respect to chassis ground.
5. When performing input to output isolation voltage testing at the module level it is recommended to tie the primary referenced terminals: Line, Neutral, LI, DD, +200V and PSRTN together and hi-pot all of these with respect to all of the secondary referenced terminals which are also tied together (this includes AP, DP, GD, VO, SB, S+ and S-).

PFC50W-28V

(115Vac, 47- 800Hz Input)

50W, 28V/1.8A Single Output,

Airborne PFC Power Module



EFFICIENCY CURVE

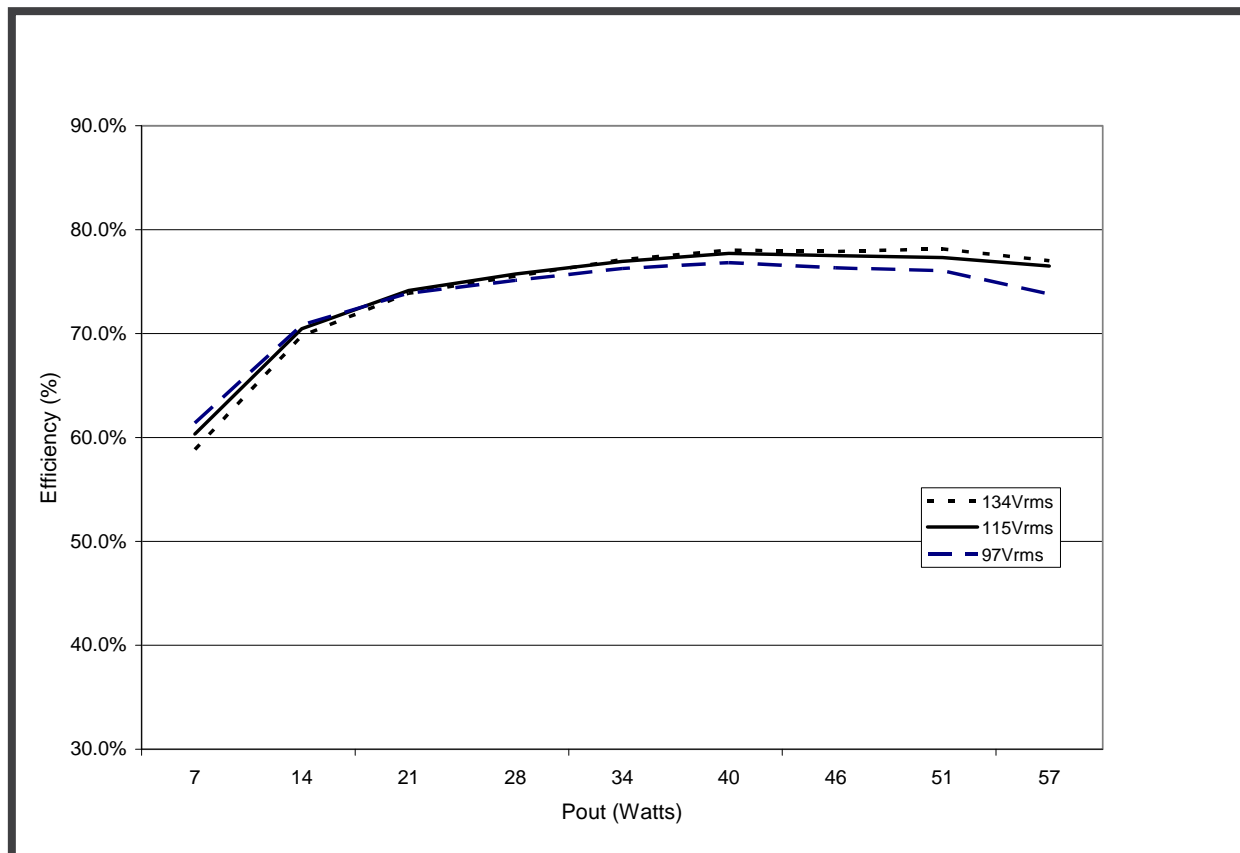

PFC50W-28V

(115Vac, 47- 800Hz Input)

50W, 28V/1.8A Single Output,

Airborne PFC Power Module



APPLICATIONS' INFORMATION

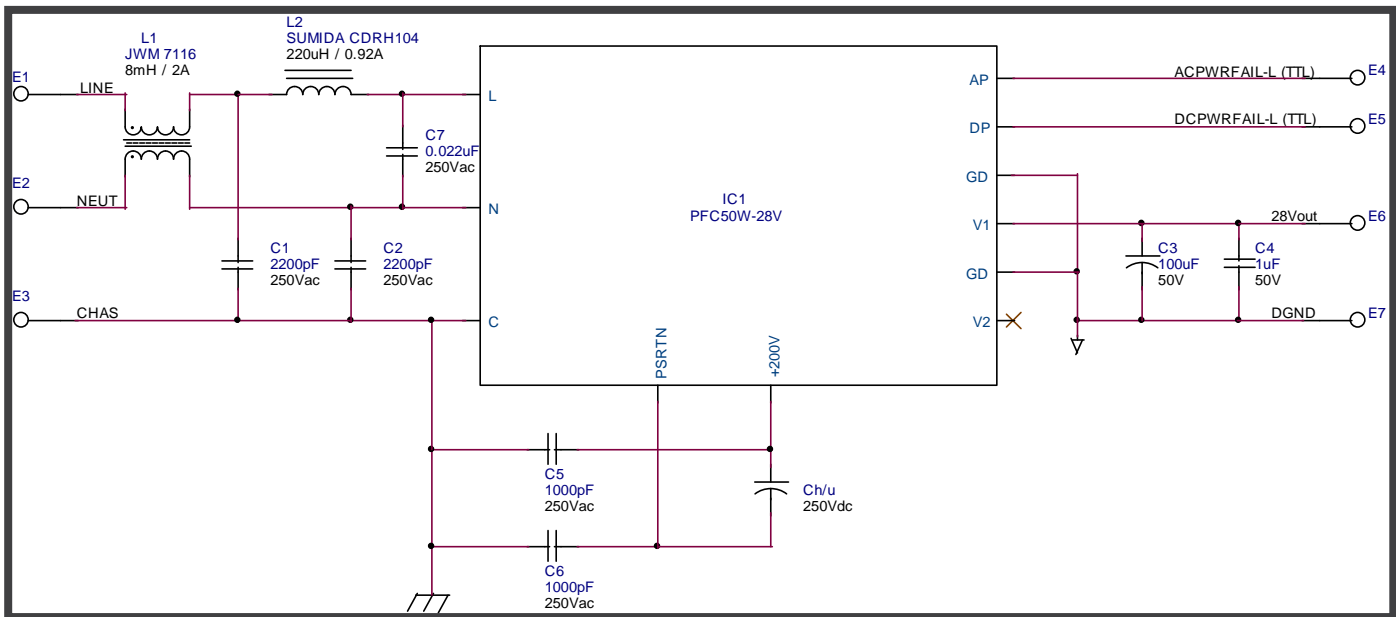

Typical Application Circuit

PFC50W-28V

(115Vac, 47- 800Hz Input)

50W, 28V/1.8A Single Output,

Airborne PFC Power Module



HOLD-UP TIME

The PFC50W series module provides two interconnecting pins in order to extend hold-up time with external capacitors. In order to extend module hold-up time, polarized 250V (minimum) electrolytic capacitors must be connected externally between the module's +200Vpin and PSRTN pin. Required external capacitance can be determined using the following formula:

$$E = P * (t + t_{\text{restart}}) = (0.85) * \{ \frac{1}{2} C_{h/u} (\text{total}) (V_i^2 - V_f^2) \}$$

Where,

P = output power (Watts)

t = desired hold-up time (Seconds)

t_{restart} = warm start delay of approximately 20mSec upon reapplication of input AC

C_{h/u} (total) = total hold-up capacitance (Farads), includes internal 35uF (minimum) and external capacitance

C_{h/u} (ext) = external hold-up capacitance (Farads)

0.85 factor constitutes internal DC/DC converter efficiency

V_i = Minimum PFC voltage of 194Vdc (200Vdc - 3%)

V_f = 110 Volts

$$E = P * (t + t_{\text{restart}}) = (0.85) * \{ \frac{1}{2} C_{h/u} (V_i^2 - V_f^2) \}$$

In order to hold up 50W external power for 200mSec requires:

$$C_{h/u} (\text{total}) = \{ (50W) (200\text{mSec} + 20\text{mSec}) \} \div \{ (1/2) (0.85) (194V^2 - 110V^2) \} = 1,014\mu\text{F}$$

$$C_{h/u} (\text{ext}) = C_{h/u} (\text{total}) - 35\mu\text{F} = 1014\mu\text{F} - 35\mu\text{F} = 979\mu\text{F} (\text{minimum})$$

Use of 105°C, 250Vdc, 20% tolerance snap-mount aluminum electrolytic capacitors is recommended. For the example above, a total nominal capacitance of 1,223uF would be necessary to assure the required capacitance of 979uF was achieved. Warm start delay occurs for AC power interrupts greater than 25mSec as a result of combination of time to reactivate PFC control circuitry, reinitiation of PFC soft-start cycle and reaching module power limit.

PLACEMENT, FLATNESS AND MOUNTING

The PFC50W series modules may be flush mounted and soldered to a PCB. The baseplate (topside) may be mounted to a flat surface for heatsinking or to a stand-alone heatsink. If mounting the baseplate to a flat surface a thermal interface pad is recommended as some warpage of the module's aluminum baseplate may exist. Warpage of the baseplate surface (including bow and twist) occurs in the manufacturing of the internal thermal clad circuit board and is a result of high temperatures required during the lamination process as well as during the panel cutting process. Baseplate warpage is limited to 0.04" per 5" unit length. Temperature activated thermally conductive interface pads, such as Chomerics' T725 series, are suitable interface pads for this application.

The PFC50W module contains 4 corner threaded #4 mounting holes (see mechanical diagram for details). The standard mounting hole configuration is partially threaded; threaded approximately 0.44" through from the baseplate side of the module.

PFC50W-28V

(115Vac, 47- 800Hz Input)

50W, 28V/1.8A Single Output,

Airborne PFC Power Module



SOLDERING INFORMATION

In order to minimize mechanical force exerted on the module pins, the module should be mechanically fastened to the printed circuit board prior to soldering each of the I/O pins. The pins are soldered internally to the module's horizontal through-hole circuit board using a high temperature solder that allows for application of high heat for long time durations when soldering the module to an external circuit board without concern for re-flow of the internal solder joints. The allowable heat application versus time duration curve is shown below and should be adhered to in order to prevent re-flow of the module pins internal solder joints.

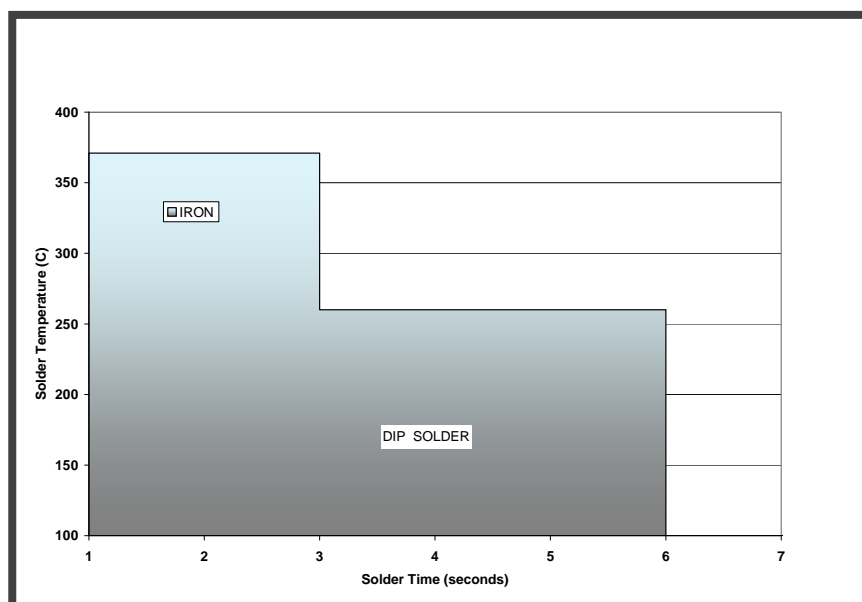

ROUTING CONSIDERATIONS

Assure there is at least 4.2mm between primary referenced and secondary referenced signals. Secondary referenced signals include AP, DP, V1 and GD. Avoid routing secondary referenced signals directly beneath module on component layer.

CAPACITIVE LOADING AND PROPER POWER-UP CONSIDERATIONS

Avoid applying full (1.8A) load current to the module's output prior to allowing the output to reach at least 10Vdc to avoid module latch-up when starting. Module latch-up can occur under certain power-up modes (e.g., low line) if the module enters internal power-limit prior to its internal bias voltages reaching minimum operating levels. If implementing active loading on the modules output (constant current sink), assure that the turn-on voltage of the active load instrument is set to at least 10Vdc. If implementing external bulk capacitors on the module's 28V output, assure proper power-up under all input line and output load conditions.

PFC50W-28V

(115Vac, 47- 800Hz Input)

50W, 28V/1.8A Single Output,

Airborne PFC Power Module



EMI CONSIDERATIONS

Use of a chassis ground plane beneath module on first internal circuit board layer (beneath component layer) of PCB is recommended. Assure that sufficient isolation distance exists between chassis plane and each of the modules input and output pins such that there is at least 4.2mm between primary referenced and secondary referenced signals. Although the PFC50W series modules contain internal common-mode and differential mode input filtering the use of a small external inductive based line filter is recommended for EMI compliance. See application circuit for suggested filter arrangement. Reduce or eliminate line-to-line capacitance (C7) for applications operating at low power levels (<20W output) as it may have an adverse effect on input current harmonic distortion at higher line frequencies (e.g., 800Hz).

If external hold-up capacitors are more than 3 inches away from module, 1000pF decoupling capacitors (line-to-earth rated) should be installed between +200V signal and chassis ground and PSRTN signal and chassis ground in close proximity to respective module terminals.

In order to reduce differential switching noise on the DC output voltage, adding a parallel combination of low ESR electrolytic and MLCC ceramic capacitors from V1 to GD is recommended. Recommended low ESR electrolytic capacitors include United Chemicon MVE series for the 28V output and Panasonic ECJ series for the MLCC capacitors.

THERMAL CONSIDERATIONS

There is no derating required for module output power up to the module baseplate temperature of 100°C. Beyond this temperature the module will shutdown. In order to assure the baseplate temperature remains below 100°C additional heatsinking or forced airflow may be required. In order to estimate baseplate temperature and whether external heatsinking or airflow is necessary, apply the following formulas:

$$T_{\text{baseplate}} = T_{\text{ambient}} + (P_{\text{diss}})(\Theta_{\text{s-a}})$$

Where:

$T_{\text{baseplate}}$ = module baseplate temperature in °C,

T_{ambient} = ambient air temperature in °C,

$\Theta_{\text{s-a}}$ = thermal resistance from module baseplate to ambient air in °C/W without external heatsink,

eff = worst case module efficiency from appropriate curve,

$P_{\text{diss}} = \{(P_{\text{out}} \div \text{eff}) - P_{\text{out}}\}$ in watts

As an example,

Assume a desired output power of 50W at low line operation (97Vrms) with a maximum ambient temperature of 70°C. The following formula would apply:

$$T_{\text{baseplate}} = 70^{\circ}\text{C} + \{(50\text{W} / 0.761) - 50\text{W}\} (3.4^{\circ}\text{C}/\text{W}) = 124^{\circ}\text{C}$$

Therefore either an external heatsink would be required or forced airflow such that $\Theta_{\text{s-a}}$ was reduced to:

$$\Theta_{\text{s-a}} < \{(T_{\text{baseplate}} - T_{\text{ambient}}) \div P_{\text{diss}}\}$$

$$\Theta_{\text{s-a}} < \{100^{\circ}\text{C} - 70^{\circ}\text{C}\} \div \{(50\text{W} / 0.761) - 50\text{W}\} < 1.91^{\circ}\text{C}/\text{W}$$