

PFC50W-5V-PBF

(115Vac, 47- 800Hz Input)

50W, 5V/ 10A Single Output,

Airborne PFC Power Module



Targeting low power avionics' applications, the **PFC50W-5V-PBF** module provides an isolated 5V output with an integral PFC input converter stage. It meets the most stringent airborne requirements including those for variable frequency 115Vac generator systems over the wide frequency range of 360-800Hz and RTCA/DO-160F category M emissions (see note 7).

Utilizing thermal-clad circuit board technology and low profile planar magnetics, thermal gradients between heat dissipating components and the module baseplate are minimized while maintaining a low 0.75" profile. Accurate output regulation is assured by implementation of the module's remote sense feature while efficiency is optimized as a result of synchronous MOSFET rectification.

The **PFC50W-5V-PBF** is capable of providing uninterrupted ride-through at full output load during momentary input AC brown-out conditions for up to 5mSec. Hold-up time is readily expanded by connecting external electrolytic capacitors to the PFC output pins provided. Standard protection features are built-in in to assure years of fault-tolerant and reliable operation in the harshest environments.

Weighing less than 18 ounces, the **PFC50W-5V-PBF** is housed in a silicon-based encapsulated enclosure with outer dimensions of 5.0" x 3.0" x 0.75". Four corner mounting holes are included to facilitate system mounting. The **PFC50W-5V-PBF** is intended for low-profile PCB mount applications where the topside baseplate can be flush mounted to LRU chassis sidewalls or a stand-alone heatsink.

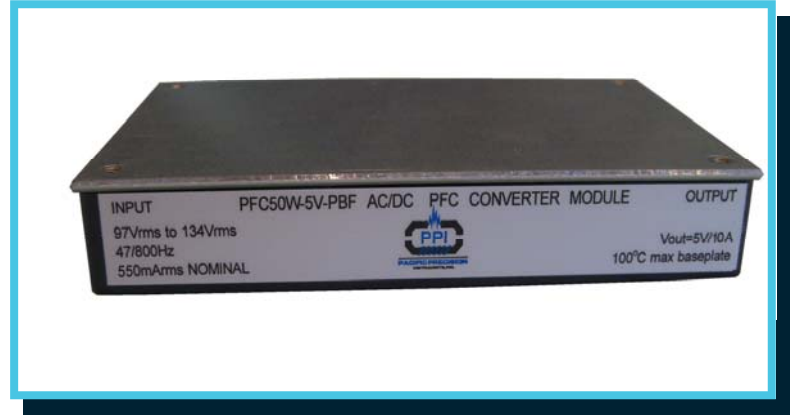

FEATURES

	Meets both RTCA/DO-160F, section 16, and Airbus ABD0100.1.8 issue D for power factor and input current harmonic distortion levels over the wide frequency operating range (360Hz – 800Hz) at ½ to full rated load
	Wide input range: 96Vrms – 134Vrms, 47 – 800Hz
	Complies with RTCA/DO-160F for conducted emissions, susceptibility and power input (section 16), see note 7
	Active inrush current limiting: 6Apk typical, 7Apk maximum
	Size: 5.0" x 3.0" x 0.75", Weight: less than 18 ounces
	Tightly regulated and isolated low voltage output: 5V/ 10A
	Remote sense capability
	Overcurrent protection with foldback current limiting
	Output overvoltage protection (5.9V set point) with automatic restart
	PFC output overvoltage protection with automatic restart (internal 200Vdc PFC output)
	Over-temperature shutdown with automatic restart (baseplate at or above 100°C)
	AC input and DC output valid status lines (TTL)
	MTBF: 675,000 Hours (RAIC 217Plus, Aic, 50°C operating temperature, 65% DC, 2190 Cycles/ yr.)

PFC50W-5V-PBF

(115Vac, 47- 800Hz Input)

50W, 5V/ 10A Single Output,

Airborne PFC Power Module



PERFORMANCE SUMMARY

PARAMETER	SPECIFICATIONS
Voltage regulation (1)	+5.03Vdc +/-1.5%
Rated output current	10A
Minimum load	0.2A
Pk-Pk Ripple + Noise (20MHz BW) (2)	100mVpp
Module Efficiency	78% typical
Output overcurrent threshold (3)	12A
Output overvoltage set-point (4)	5.9V
PFC output overvoltage set-point (4)	246V
Isolation Voltage (5) (Input to Output & Input to Chassis)	1500Vac
Output ride-through / full load (6)	5mSec
MTBF (RAIC 217Plus, Aic, 50°C)	675,000 Hours

Notes:

1. With remote sense line connected at output pins (looped back).
2. Can be reduced with inclusion of external capacitors, see application section for details.
3. +/-1.5A with foldback current limiting and auto recovery into full load.
4. Auto recovery.
5. 1500Vac, 60Hz for 60 seconds without arc or damage; 3.0mA maximum leakage current (line-to-earth capacitors installed).
6. 44uF internal hold-up capacitance, expandable by external capacitors. May be affected by warm start delay, see application section for details.
7. Requires external filter (differential and common mode) installed on power lines for full compliance, see application section for details.

TEMPERATURE CHARACTERISTICS

*AIRFLOW (LFM)	THERMAL IMPEDANCE (θ_{s-a}) (no external heatsink)
0 LFM	3.4 °C/W
250 LFM	1.0 °C/W
500 LFM	0.6 °C/W

* Air velocity measured using a digital anemometer positioned within an airflow duct 3" X 3" above top of module



PFC50W-5V-PBF

(115Vac, 47- 800Hz Input)

50W, 5V/ 10A Single Output,
Airborne PFC Power Module



BLOCK DIAGRAM

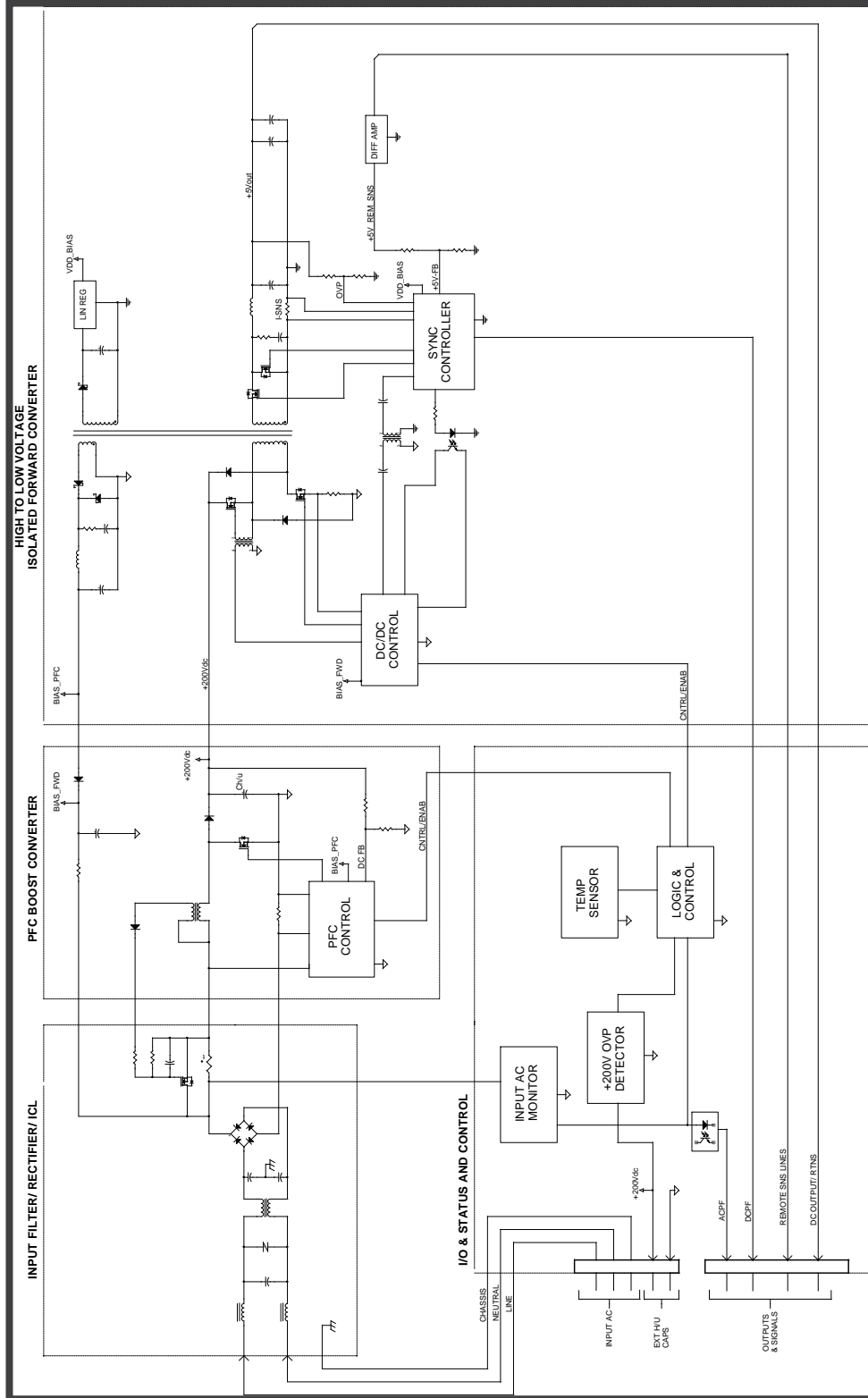

PFC50W-5V-PBF

(115Vac, 47- 800Hz Input)

50W, 5V/ 10A Single Output,

Airborne PFC Power Module



MECHANICAL DIAGRAM

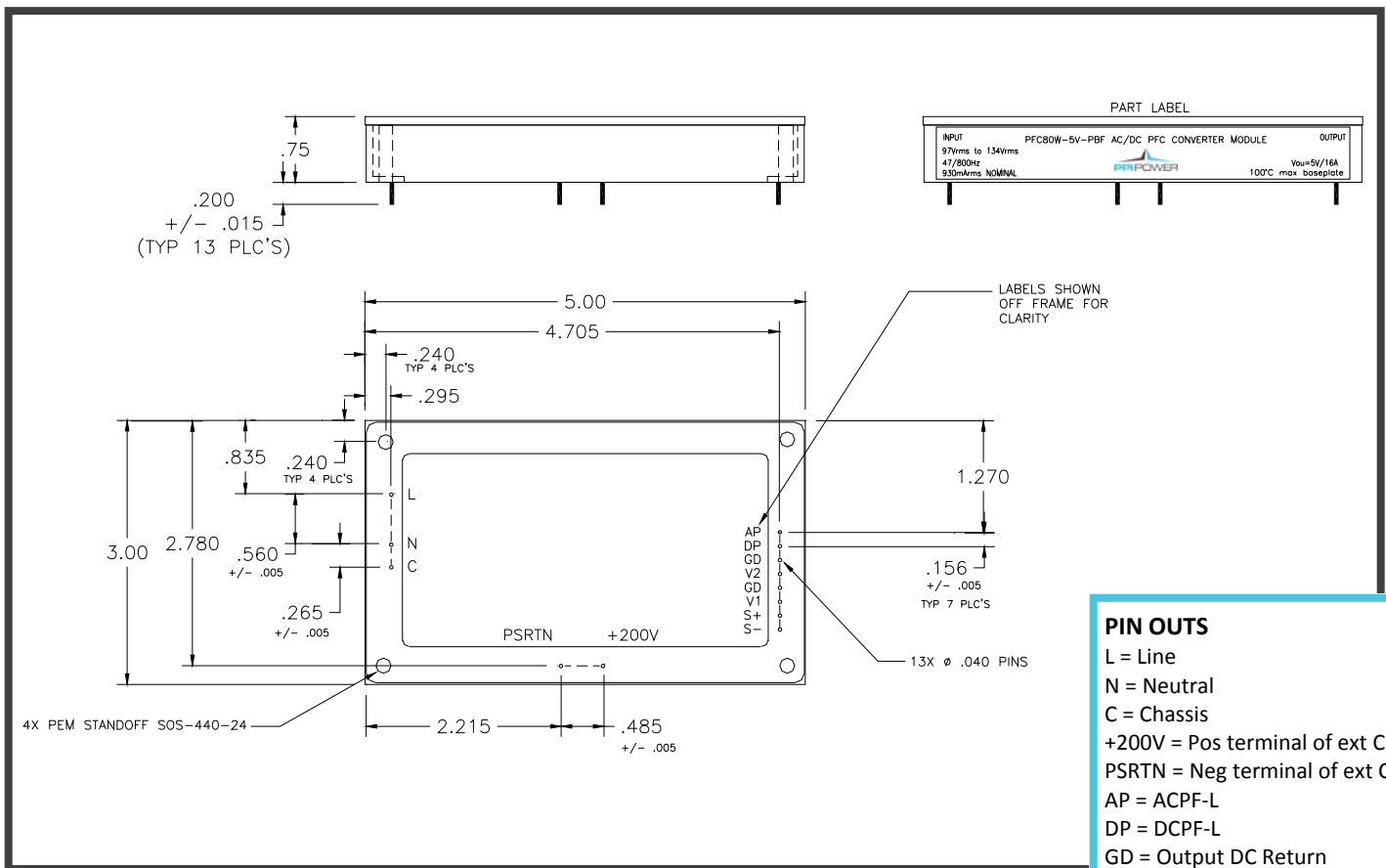

* BASEPLATE FLATNESS

Maximum warpage not to exceed
0.04" per 5" unit length.

A DETAILED OUTLINE DRAWING CAN BE FURNISHED UPON REQUEST

PFC50W-5V-PBF

(115Vac, 47- 800Hz Input)

50W, 5V/ 10A Single Output,

Airborne PFC Power Module



ELECTRICAL SPECIFICATIONS

Unless otherwise specified the following test conditions apply: Ta = 25°C, constant active load applied to output, Ch/u (external) = 940uF/ 250V, Cout = 330uF/ 10V, Vin = 115Vrms, 360Hz – 800Hz, <1.25% sinusoid.

INPUT CHARACTERISTICS

PARAMETER	PFC50W-5V-PBF	REMARKS	NOTES
INPUT VOLTAGE RANGE	96 – 134Vrms	Complies with normal / abnormal input voltages per DO-160F, sect. 16.	2
MUST START VOLTAGE	96Vrms minimum	Module will start and remained enabled for input voltage in the range of 96Vrms < Vin < 134Vrms.	2
MUST INHIBIT VOLTAGE	89Vrms maximum	Module output will inhibit following ~800mSec turn-off delay upon detection of input undervoltage $\leq 89Vrms$. 5V output to disable monotonically and remain disabled as long as input voltage remains $\leq 89Vrms$.	2
INPUT FREQUENCY RANGE	47 – 800Hz	Reduced distortion performance below 360Hz.	2
EFFICIENCY	72% minimum	50% to 100% output loading (25W-50W). Typical full load efficiency = 78% (see efficiency curve).	2
LEAKAGE CURRENT	< 2mArms	AC Line / Neutral to Chassis at 115Vrms / 400Hz.	1
INRUSH CURRENT	< 7Apk	Cold or warm start; 6Apk typical.	2
TOTAL HARMONIC DISTORTION (INPUT CURRENT)	< 5.5%	50% to 100% output load (25W-50W).	2
INDIVIDUAL HARMONICS AC CLEAN	EVEN: <1% If / n (n < 10) EVEN: <0.1%If (n ≥ 10) ODD: <30% If / n ODD TRIPLENS:<15% If /n	If = Fundamental current Vthd < 1.25%, n = order of harmonic (1 - 40) 50% - 100% output load (25W-50W). Harmonics < 10mA disregarded.	1

PFC50W-5V-PBF

(115Vac, 47- 800Hz Input)

50W, 5V/ 10A Single Output,

Airborne PFC Power Module



INPUT CHARACTERISTICS—CONTINUED

PARAMETER	PFC50W-5V-PBF	REMARKS	NOTES
INDIVIDUAL HARMONICS DISTORTED INPUT	EVEN: $<1\% I_f / n + 1.25V_n$ ($n < 10$) EVEN: $<0.1\% I_f + 1.25V_n$ ($n \geq 10$) ODD: $<30\% I_f / n + 1.25V_n$ ODD TRIPLENS: $<15\% I_f / n + 1.25V_n$	I_f = Fundamental current $V_{thd} > 10\%$ (clipped method), n = order of harmonic (1 - 40) V_n = corr input voltage harmonic. 50% - 100% output load (25W-50W). Harmonics $< 10mA$ disregarded.	1
POWER FACTOR	0.98 min	$P_{out} > 25W$ at 400Hz, $P_{out} > 40W$ at 800Hz.	2
CREST FACTOR (CURRENT)	1.314 – 1.514	Ratio of peak / RMS.	1
START-UP TIME	$< 750mSec$	5V output within proper regulation.	2
CONDUCTED EMISSIONS	RTCA/DO-160F	Section 21, category M.	1, 4
STORAGE TEMP RANGE	-55°C to +100°C	Non-operational.	1
OPERATING TEMP RANGE	-40°C to +70°C	Observe maximum baseplate temperature of +100°C.	1
OVERTEMPERATURE SHUTDOWN	100°C \pm 8°C	Supply is inhibited at or above 100°C. Auto re- start occurs at $\sim 90^\circ C$ baseplate temperature.	1

PFC50W-5V-PBF

(115Vac, 47- 800Hz Input)

50W, 5V/ 10A Single Output,

Airborne PFC Power Module



OUTPUT CHARACTERISTICS

PARAMETER	PFC50W-5V-PBF	REMARKS	NOTES
RATED OUTPUT POWER	50W	Continuous. Observe maximum allowable baseplate temperature; see application information for details.	2
OUTPUT VOLTAGE	5.03Vdc +/-1.5%	With remote sense lines connected at output pins. Output may deviate from this level based on remote sense feedback signal applied.	2
REMOTE SENSE LINES	Maximum 700mV drop in output lines combined	Maximum allowable margin-up is 700mV for a 5.73Vdc output. If not used at point-of-load, sense lines should be looped back at module output pins. See application information for details. No damage will occur if sense lines are not connected.	1
OUTPUT OVERCURRENT THRESHOLD	12A +/- 1.5A	Output voltage will foldback for load demands > 10A. Output will recover automatically into full load when load demand falls to 10A or less. No damage will occur to module during indefinite output short circuit conditions.	2
TEMPERATURE STABILITY COEFFICIENT	0.05% / °C	Output voltage variation with temperature (500uV / °C).	1
OUTPUT RIPPLE + NOISE	100mVpp	20MHz bandwidth. Ripple + noise can be reduced by implementing external capacitors. See application information for details.	2
LINE REGULATION	<0.5%	Output deviation for +/- 20% step change in input voltage.	1
TRANSIENT RESPONSE	< 100uSec for output to recover within 50mV of static output following a step change in load current from full load to half load or half load to full load	50% step change in output load. 10uSec rise/fall time. Full load to half load or half load to full load.	1
MINIMUM LOAD	0.2A	A minimum load of 0.2A is suggested if performing repetitive start-up sequences (into otherwise no load) for proper output regulation for all operating conditions. No damage will result to module if no minimum load is provided.	2
HOLD-UP TIME	5mSec minimum	No external hold-up capacitor attached. Requires external 250V rated capacitors to extend hold-up time.	1



PFC50W-5V-PBF

(115Vac, 47- 800Hz Input)

50W, 5V/ 10A Single Output,

Airborne PFC Power Module



OUTPUT CHARACTERISTICS—CONTINUED

PARAMETER	PFC50W-5V-PBF	REMARKS	NOTES
HOLD-UP TIME	200mSec minimum	Full 50W output load, external 940uF hold-up capacitance attached.	2
MAXIMUM EXTERNAL HOLD-UP CAPACITANCE	3700uF	Specified in order to not overstress the internal inrush current limiting circuit.	1
ISOLATION VOLTAGE INPUT TO CHASSIS	1500Vac, 60Hz	No arcing or damage for 60-second test duration (3.0mArms max leakage).	2
ISOLATION VOLTAGE INPUT TO OUTPUT	1500Vac, 60Hz	No arcing or damage for 60-second test duration (3.0mArms max leakage).	2
ISOLATION VOLTAGE OUTPUT TO CHASSIS	250Vdc	No arcing or damage for 60-second test duration (100Mohm min).	1
DCPWRFAIL-L (DP)	Transitions to TTL low (0.5Vmax) when 5Vdc output is detected outside of proper regulation window	TTL level, 3mA max sink current. Time to activation on a fault is 1mSec typical, 2.5mSec maximum.	2
ACPWRFAIL-L (AP)	Transitions to TTL low level (0.5Vmax) upon detection of invalid input AC ($\leq 89V_{rms}$ from 0%-100% load)	TTL level, 16mA max sink current, 5mSec maximum delay time to activate on loss of input AC.	2
PFC 200Vdc OUTPUT	200Vrms \pm 3%	10W \leq Pout < 50W.	2, 3
MINIMUM DC/DC CONVERTER OPERATING VOLTAGE	90Vdc	Minimum amplitude for PFC output that will guarantee proper output regulation for the 5V output.	1
OUTPUT OVERVOLTAGE PROTECTION (5V OUTPUT)	5.9V \pm 3%	Pulse by pulse protection (inner loop), auto-recovery. Activation time <100uSec for overvoltage detection at a level >18% above static operating level.	1
OUTPUT OVERVOLTAGE PROTECTION (PFC 200Vdc OUTPUT)	246V \pm 3%	PFC output is clamped to this level if control loop regulation is lost. Auto-recovery when fault condition clears.	1

Notes:

1. Ensured by design, not 100% tested in production.
2. 100% tested for specification compliance in production.
3. 200Vdc PFC output voltage tolerance is \pm 5% for Pout < 10W.
4. Requires external filter (differential and common mode) installed on power lines for full compliance, see application section for details.



PFC50W-5V-PBF

(115Vac, 47- 800Hz Input)

50W, 5V/ 10A Single Output,

Airborne PFC Power Module



EFFICIENCY CURVE

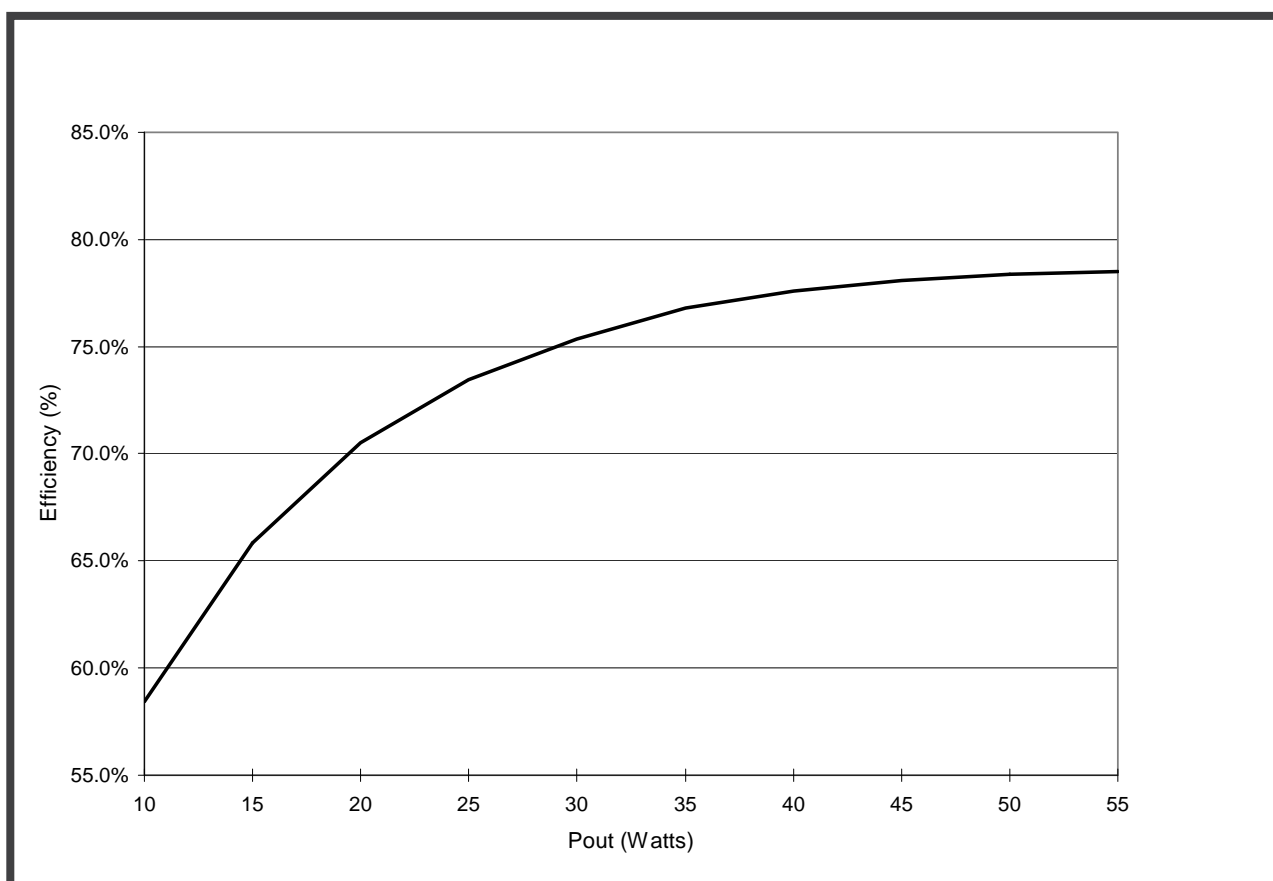

PFC50W-5V-PBF

(115Vac, 47- 800Hz Input)

50W, 5V/ 10A Single Output,
Airborne PFC Power Module



APPLICATIONS' INFORMATION

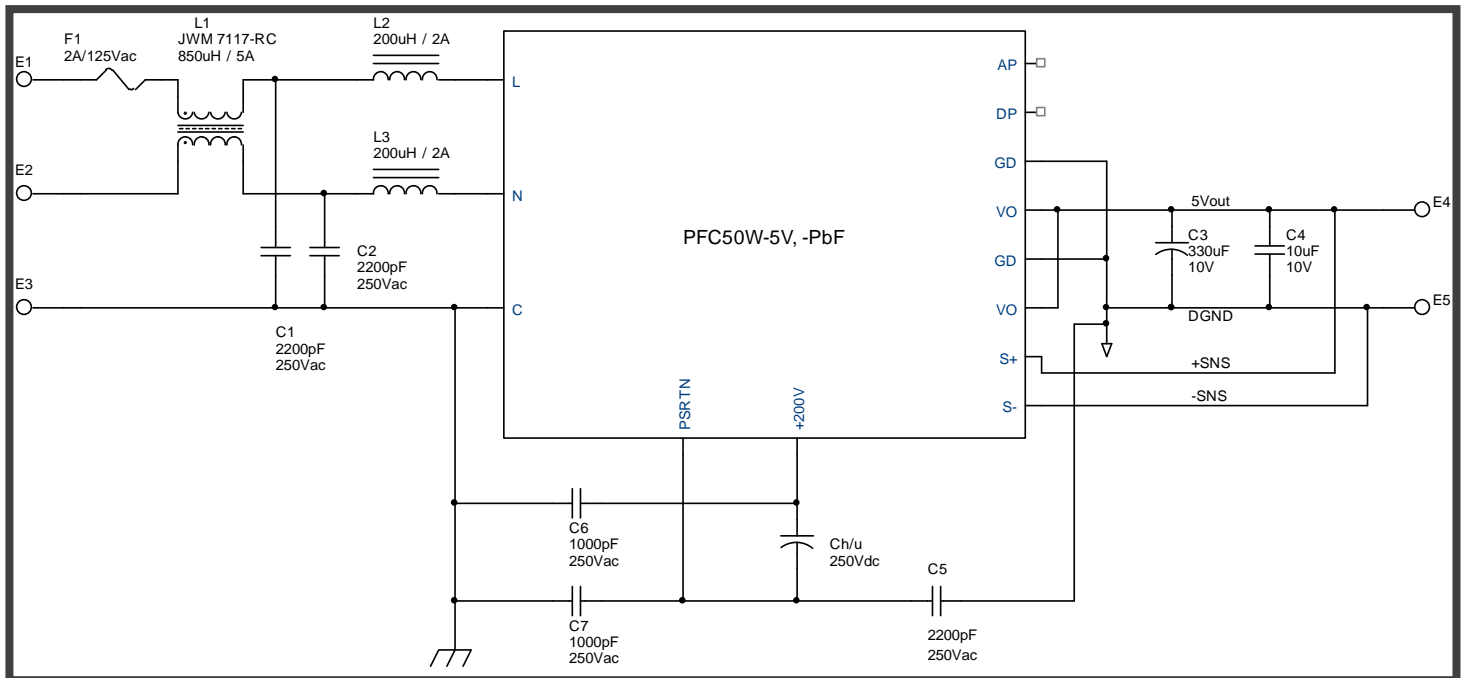

Typical Application Circuit

PFC50W-5V-PBF

(115Vac, 47- 800Hz Input)

50W, 5V/ 10A Single Output,

Airborne PFC Power Module



HOLD-UP TIME

The PFC50W-5V-PBF module provides two interconnecting pins in order to extend hold-up time with external capacitors. In order to extend module hold-up time, polarized 250V (minimum) electrolytic capacitors must be connected externally between the module's +200Vpin and PSRTN pin. The module's internal DC/DC converter operates over the range of 210Vdc to 90Vdc; provided the "+200Vdc" amplitude is within this range, the 5V output will remain within proper regulation. 200Vdc is the nominal value when input AC is present. During momentary power interrupts, the required external capacitance can be determined using the following formula:

$$E = P * (t + t_{\text{restart}}) = (0.86) * \{ \frac{1}{2} C_{h/u} (\text{total}) (V_i^2 - V_f^2) \}$$

Where,

P = output power (Watts)

t = desired hold-up time (Seconds)

t_{restart} = warm start delay of approximately 20mSec, typical 35mSec maximum, upon reapplication of input AC

C_{h/u (total)} = total hold-up capacitance (Farads), includes internal 35uF (minimum) and external capacitance

C_{h/u (ext)} = external hold-up capacitance (Farads)

0.86 factor constitutes internal DC/DC converter efficiency

V_i = Minimum PFC voltage of 194Vdc (200Vdc - 3%)

V_f = 90 Volts

In order to hold up 50W external power for 200mSec requires:

$$C_{h/u} (\text{total}) = \{ (50W) (200\text{mSec} + 35\text{mSec}) \} \div \{ (1/2) (0.86) (194V^2 - 90V^2) \} = 925\mu\text{F}$$

$$C_{h/u} (\text{ext}) = C_{h/u} (\text{total}) - 35\mu\text{F} = 925\mu\text{F} - 35\mu\text{F} = 890\mu\text{F} (\text{minimum})$$

Use of 105°C, 250Vdc, 20% tolerance snap-mount aluminum electrolytic capacitors is recommended. For the example above, a total nominal capacitance of 1,110uF would be necessary to assure the required capacitance of 890uF was achieved. Warm start delay occurs for AC power interrupts greater than 25mSec as a result of combination of time to reactivate PFC control circuitry, reinitiation of PFC soft-start cycle and reaching module power limit.

PLACEMENT, FLATNESS AND MOUNTING

The PFC50W-5V-PBF module may be flush mounted and soldered to a PCB. The baseplate (topside) may be mounted to a flat surface for heatsinking or to a stand-alone heatsink. If mounting the baseplate to a flat surface a thermal interface pad is recommended as some warpage of the module's aluminum baseplate may exist. Warpage of the baseplate surface (including bow and twist) occurs in the manufacturing of the internal thermal clad circuit board and is a result of high temperatures required during the lamination process as well as during the panel cutting process. Baseplate warpage is limited to 0.04" per 5" unit length. Temperature activated thermally conductive interface pads, such as Chomeric's T725 series, are suitable interface pads for this application.

The PFC50W-5V-PBF module contains 4 corner threaded #4 mounting holes (see mechanical diagram for details). The standard mounting hole configuration is partially threaded; threaded approximately 0.44" through from the baseplate side of the module.

PFC50W-5V-PBF

(115Vac, 47- 800Hz Input)

50W, 5V/ 10A Single Output,

Airborne PFC Power Module



SOLDERING INFORMATION

In order to minimize mechanical force exerted on the module pins, the module should be mechanically fastened to the printed circuit board prior to soldering each of the I/O pins. The pins are soldered internally to the module's horizontal through-hole circuit board using a high temperature solder that allows for application of high heat for long time durations when soldering the module to an external circuit board without concern for re-flow of the internal solder joints. The allowable heat application versus time duration curve is shown below and should be adhered to in order to prevent re-flow of the module pins internal solder joints.

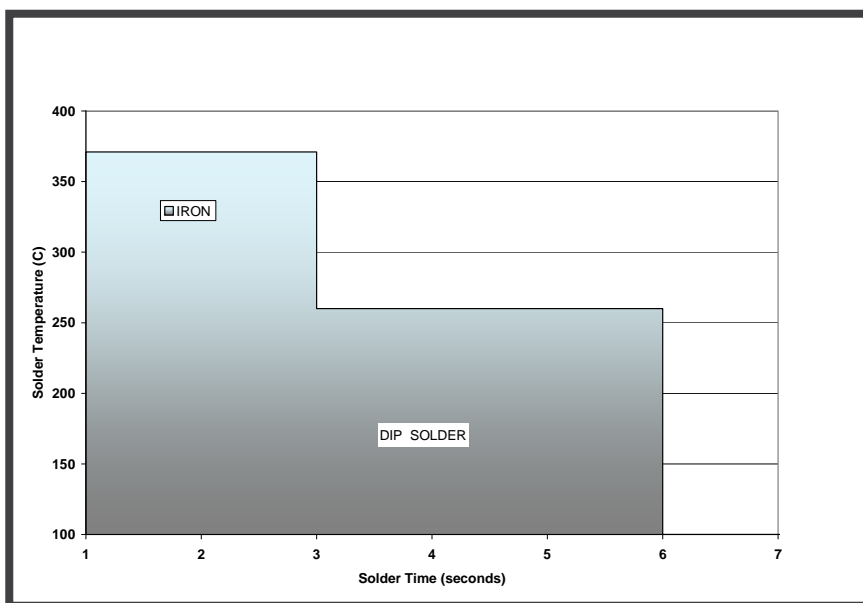

ROUTING CONSIDERATIONS

Assure there is at least 4.2mm between primary referenced and secondary referenced signals. Secondary referenced signals include AP, DP, VO, GD, S+ and S-. Avoid routing secondary referenced signals directly beneath module on component layer.

REMOTE SENSE LINES

Remote sense capability is provided in order to “margin-up” the 5V output to overcome small system level voltage drops in traces and connectors. If using the remote sense lines, the maximum allowable system level voltage drop (or combined differential voltage between Vout and +SNS and DGND and -SNS) is 700mV. Exceeding this amplitude may force the module's overvoltage protection circuit to activate. If not using the remote sense line feature at a remote point-of-load, each sense line should be terminated at the output pins of the module (+SNS to Vout and -SNS to DGND). Remote sense lines should be connected directly to the +5V and DGND power forms prior to any additional inductive filter elements that may be included.

PFC50W-5V-PBF

(115Vac, 47- 800Hz Input)

50W, 5V/ 10A Single Output,

Airborne PFC Power Module



EMI CONSIDERATIONS

Use of a chassis ground plane beneath module on first internal circuit board layer (beneath component layer) of PCB is recommended. Assure that sufficient isolation distance exists between chassis plane and each of the modules input and output pins such that there is at least 4.2mm between primary referenced and secondary referenced signals. Although the PFC50W-5V-PBF module contains internal common-mode and differential mode input filtering the use of a small external power line filter is recommended for EMI compliance. See typical application circuit for recommended components and values. Avoid adding line-to-line capacitance at low power levels (<25W output) as they may have an adverse effect on input current harmonic distortion at higher line frequencies (e.g., 800Hz). See application circuit for suggested filter arrangement.

If external hold-up capacitors are more than 3 inches away from module, 1000pF decoupling capacitors (line-to-earth rated) should be installed between +200V signal and chassis ground and PSRTN signal and chassis ground in close proximity to respective module terminals.

In order to reduce differential switching noise on the DC output voltage and to reduce overshoot on the 5V output at start-up, adding a parallel combination of low ESR electrolytic and MLCC ceramic capacitors from VO to GD is recommended. Recommended low ESR electrolytic capacitors include Panasonic FC series for the 5V output; MLCC capacitors include Panasonic ECJ series.

THERMAL CONSIDERATIONS

There is no derating required for module output power up to the module baseplate temperature of 100°C. Beyond this temperature the module will shutdown. In order to assure the baseplate temperature remains below 100°C additional heatsinking or forced airflow may be required. In order to estimate baseplate temperature and whether external heatsinking or airflow is necessary, apply the following formulas:

$$T_{\text{baseplate}} = T_{\text{ambient}} + (P_{\text{diss}})(\Theta_{\text{s-a}})$$

Where:

$T_{\text{baseplate}}$ = module baseplate temperature in °C,

T_{ambient} = ambient air temperature in °C,

$\Theta_{\text{s-a}}$ = thermal resistance from module baseplate to ambient air in °C/W without external heatsink,

eff = module efficiency from efficiency curve,

$P_{\text{diss}} = \{(P_{\text{out}} \div \text{eff}) - P_{\text{out}}\}$ in watts

As an example,

Assume a desired output power of 50W at nominal line operation (115Vrms) with a maximum ambient temperature of 70°C. The following formula would apply:

$$T_{\text{baseplate}} = 70^{\circ}\text{C} + \{(50\text{W} / 0.79) - 50\text{W}\} (3.4^{\circ}\text{C/W}) = 115^{\circ}\text{C}$$

Therefore either an external heatsink would be required or forced airflow such that $\Theta_{\text{s-a}}$ was reduced to:

$$\Theta_{\text{s-a}} < \{(T_{\text{baseplate}} - T_{\text{ambient}}) \div P_{\text{diss}}\}$$

$$\Theta_{\text{s-a}} < \{100^{\circ}\text{C} - 70^{\circ}\text{C}\} \div \{(50\text{W} / 0.79) - 50\text{W}\} < 2.26^{\circ}\text{C/W}$$

