

PFC50W-SYNC-3.3V

(115Vac, 47- 800Hz Input)

50W, 3.3V/15A Single Output,

Airborne PFC Power Module



Targeting low power avionics' applications, the **PFC50W-SYNC-3.3V** module provides an isolated 3.3V output with an integral PFC input converter stage. It meets the most stringent airborne requirements including those for variable frequency 115Vac generator systems over the wide frequency range of 360-800Hz and RTCA/DO-160E category M emissions.

Utilizing thermal-clad circuit board technology and low profile planar magnetics, thermal gradients between heat dissipating components and the module baseplate are minimized while maintaining a low 0.75" profile. Accurate output regulation is assured by implementation of the module's remote sense feature while efficiency is optimized by way of synchronous MOSFET rectification.

The **PFC50W-SYNC-3.3V** is capable of providing uninterrupted ride-through at full output load during momentary input AC brown-out conditions for up to 10mSec. Hold-up time is readily expanded by connecting external electrolytic capacitors to the PFC output pins provided. Standard protection features are built-in in to assure years of fault-tolerant and reliable operation in the harshest environments.

Weighing less than 18 ounces, the **PFC50W-SYNC-3.3V** is housed in a silicon-based encapsulated enclosure with outer dimensions of 5.0" x 3.0" x 0.75". Four corner mounting holes are included to facilitate system mounting. The **PFC50W-SYNC-3.3V** is intended for low-profile PCB mount applications where the topside baseplate can be flush mounted to LRU chassis sidewalls or a stand-alone heatsink.



FEATURES

	Meets both RTCA/DO-160E, section 16, and Airbus ABD0100.1.8 issue D for power factor and input current harmonic distortion levels over the wide frequency operating range (360Hz – 800Hz) at ½ to full rated load
	Wide input range: 90Vrms – 134Vrms, 47 – 800Hz
	Complies with RTCA/DO-160E for conducted emissions, susceptibility and power input (section 16)
	Active inrush current limiting: 5Apk typical, 7Apk maximum
	Size: 5.0" x 3.0" x 0.75", Weight: less than 18 ounces
	Tightly regulated and isolated low voltage output: 3.3V/15A
	Remote sense capability
	Overcurrent protection with foldback current limiting
	Output overvoltage protection (3.9V set point) with automatic restart
	PFC output overvoltage protection with automatic restart (internal 200Vdc PFC output)
	Over-temperature shutdown with automatic restart (baseplate at or above 100°C)
	AC input and DC output valid status lines (TTL)
	MTBF: 40,000 Hours, Aic category, 30°C case temperature (MIL-HDBK-217F)

PFC50W-SYNC-3.3V

(115Vac, 47- 800Hz Input)

50W, 3.3V/15A Single Output,

Airborne PFC Power Module



PERFORMANCE SUMMARY

PARAMETER	SPECIFICATIONS
Voltage regulation (1)	+3.3Vdc +/-1%
Rated output current	15A
Minimum load	0A
Pk-Pk Ripple + Noise (20MHz)	50mVpp
Module Efficiency	73% typical
Output overcurrent threshold (2)	16A
Output overvoltage set-point (3)	3.9V
PFC output overvoltage set-point (3)	246V
Isolation Voltage (4) (Input to Output & Input to Chassis)	1500Vac
Output ride-through / full load (5)	10mSec
MTBF (Aic, 30°C case)	40,000 Hours

Notes:

1. With remote sense line connected at output pins (looped back)
2. +/-1A with foldback current limiting and auto recovery into full load
3. Auto recovery
4. 1500Vac, 60Hz for 60 seconds without arc or damage; 3.0mA maximum leakage current (line-to-earth capacitors installed)
5. Expandable by external capacitors

TEMPERATURE CHARACTERISTICS

*AIRFLOW (LFM)	THERMAL IMPEDANCE (Θ_{s-a}) (no external heatsink)
0 LFM	3.4 °C/W
250 LFM	1.0 °C/W
500 LFM	0.6 °C/W

* Air velocity measured using a digital anemometer positioned within an airflow duct 3" X 3" above top of module

PFC50W-SYNC-3.3V

(115Vac, 47- 800Hz Input)

50W, 3.3V/15A Single Output,

Airborne PFC Power Module



BLOCK DIAGRAM

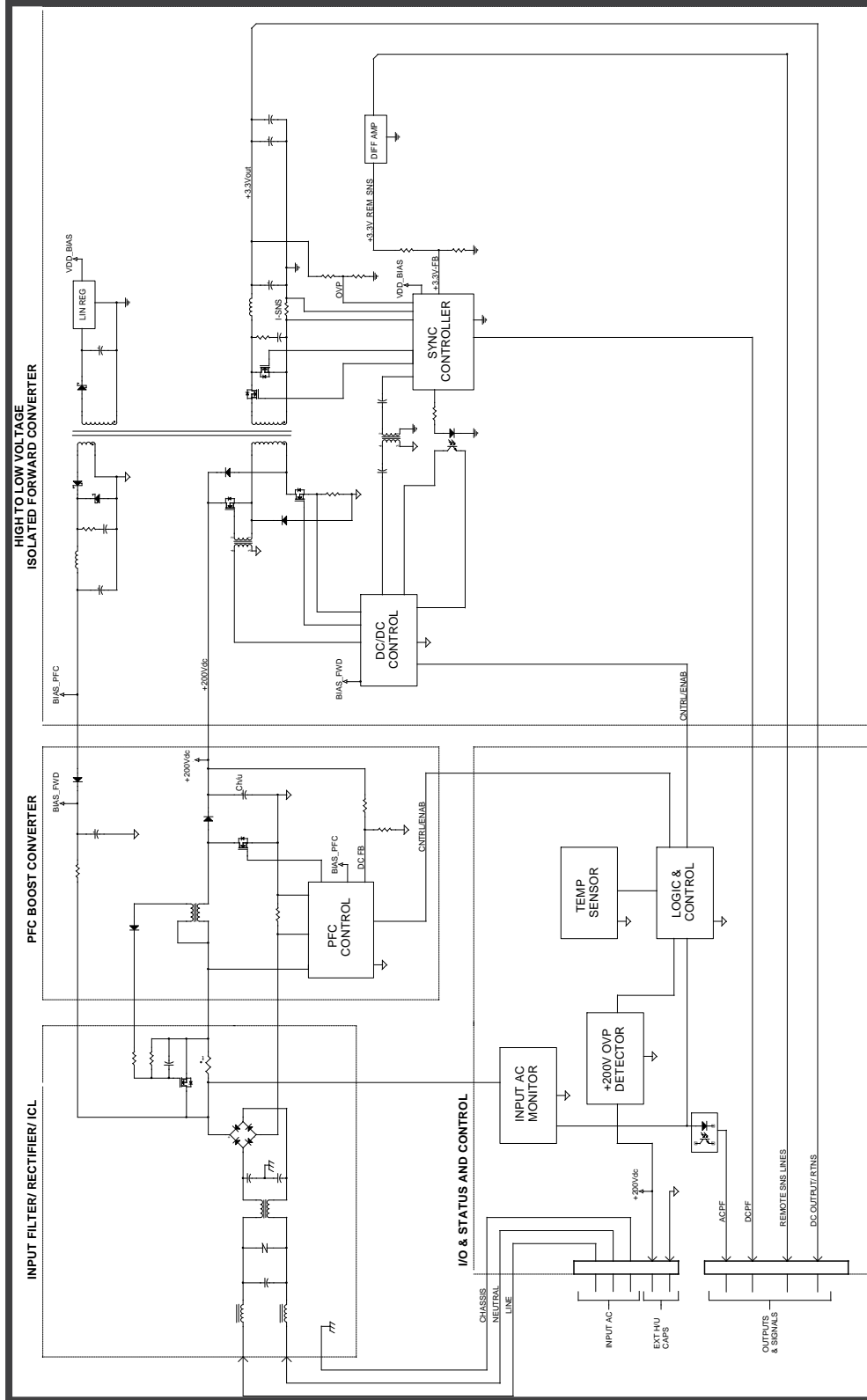

PFC50W-SYNC-3.3V

(115Vac, 47- 800Hz Input)

50W, 3.3V/15A Single Output,

Airborne PFC Power Module



MECHANICAL DIAGRAM

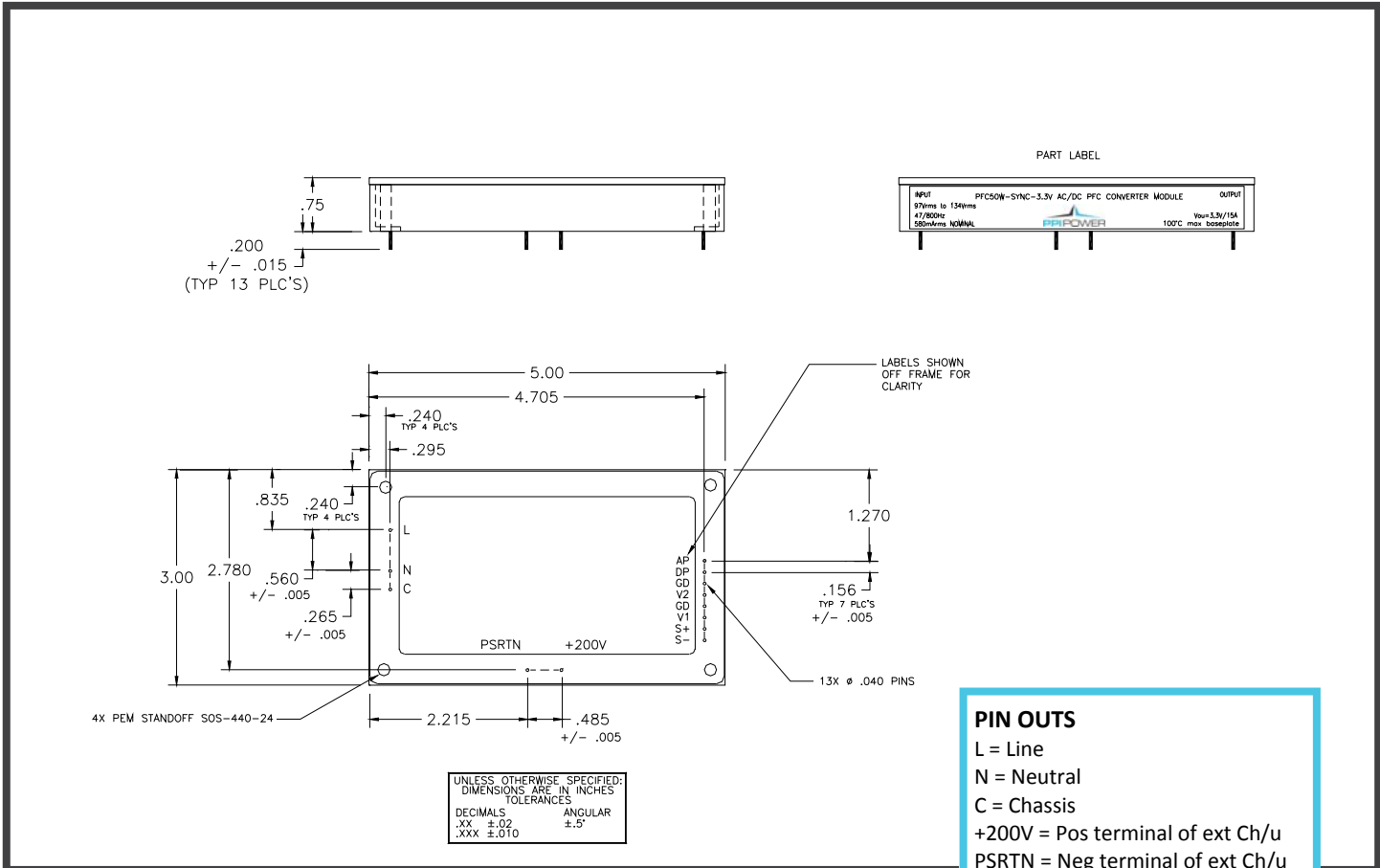

* BASEPLATE FLATNESS

Maximum warpage not to exceed
0.04" per 5" unit length.

A DETAILED OUTLINE DRAWING CAN BE FURNISHED UPON REQUEST

PFC50W-SYNC-3.3V

(115Vac, 47- 800Hz Input)

50W, 3.3V/15A Single Output,

Airborne PFC Power Module



ELECTRICAL SPECIFICATIONS

Unless otherwise specified the following test conditions apply: $T_a = 25^{\circ}\text{C}$, constant active load applied to each output, Ch/u (external) = 220uF, $V_{in} = 115\text{Vrms}$, 360Hz – 800Hz, <1.25% sinusoid.

INPUT CHARACTERISTICS

PARAMETER	PFC50W-SYNC-3.3V	REMARKS	NOTES
INPUT VOLTAGE RANGE	90 – 134Vrms	Complies with normal / abnormal input voltages per DO-160E, sect. 16.	2
INPUT UNDERVOLTAGE DISABLE	90Vrms minimum	Module will start and remained enabled for input voltage in the range of $90\text{Vrms} < V_{in} < 134\text{Vrms}$.	2
INPUT FREQUENCY RANGE	47 – 800Hz	Reduced distortion performance below 360Hz.	2
EFFICIENCY	70% minimum	50% to 100% output loading (25W to 50W). 73% typical full load efficiency.	2
LEAKAGE CURRENT	< 2mArms	AC Line / Neutral to Chassis at 115Vrms / 400Hz.	1
INRUSH CURRENT	< 7Apk	Cold or warm start; 5Apk typical.	2
TOTAL HARMONIC DISTORTION (INPUT CURRENT)	< 5%	50% to 100% output load (25W to 50W).	2
INDIVIDUAL HARMONICS AC CLEAN	EVEN: <1% I_f / n ($n < 10$) EVEN: <0.1% I_f ($n \geq 10$) ODD: <30% I_f / n ODD TRIPLENS:<15% I_f / n	I_f = Fundamental current $V_{thd} < 1.25\%$, n = order of harmonic (1 - 40) 50% to 100% load (25W to 50W).	1
INDIVIDUAL HARMONICS DISTORTED INPUT	EVEN: <1% $I_f / n + 1.25V_n$ ($n < 10$) EVEN: <0.1% $I_f + 1.25V_n$ ($n \geq 10$) ODD: <30% $I_f / n + 1.25V_n$ ODD TRIPLENS:<15% $I_f / n + 1.25V_n$	I_f = Fundamental current $V_{thd} > 10\%$ (clipped method), n = order of harmonic (1 - 40) V_n = corresponding input voltage harmonic 50% to 100% load (25W to 50W).	1
POWER FACTOR	0.90 min	$P_{out} > 20\text{W}$.	2

PFC50W-SYNC-3.3V

(115Vac, 47- 800Hz Input)

50W, 3.3V/15A Single Output,

Airborne PFC Power Module



INPUT CHARACTERISTICS—CONTINUED

PARAMETER	PFC50W-SYNC-3.3V	REMARKS	NOTES
CREST FACTOR (CURRENT)	1.314 – 1.514	Ratio of peak / RMS.	1
START-UP TIME	< 750mSec	3.3V output within proper regulation.	2
CONDUCTED EMISSIONS	RTCA/DO-160E	Section 21, category M.	1
STORAGE TEMPERATURE RANGE	-55°C to +100°C	Non-operational.	1
OPERATING TEMPERATURE RANGE	-15°C to +70°C	Observe maximum baseplate temperature of +100°C.	1
LOW TEMPERATURE INHIBIT	-22°C ± 3°C	Supply is inhibited at or below -22°C. Auto re-start occurs when temperature rises above -22° C.	1
OVERTEMPERATURE SHUTDOWN	100°C ± 4°C	Supply is inhibited at or above 100°C. Auto re-start occurs at ~ 80°C baseplate temperature.	1

PFC50W-SYNC-3.3V

(115Vac, 47- 800Hz Input)

50W, 3.3V/15A Single Output,

Airborne PFC Power Module



OUTPUT CHARACTERISTICS

PARAMETER	PFC50W-SYNC-3.3V	REMARKS	NOTES
RATED OUTPUT POWER	50W	Continuous. Observe maximum allowable baseplate temperature; see application information for details.	2
OUTPUT VOLTAGE	3.3Vdc +/-1%	With remote sense lines connected at output pins. Output may deviate from this level based on remote sense feedback signal applied.	2
REMOTE SENSE LINES	Maximum 300mV drop in output lines combined	Maximum allowable margin-up is 300mV for a 3.60Vdc output. If not used at point-of-load, sense lines should be looped back at module output pins. See application information for details. No damage will occur if sense lines are not connected.	1
OUTPUT OVERCURRENT THRESHOLD	3.3V output: 16A +/- 1A	Output voltage will foldback for load demands > 15A. Output will recover automatically into full load when load demand falls to 15A or less. No damage will occur to module during indefinite output short circuit conditions.	2
TEMPERATURE STABILITY COEFFICIENT	0.05% / °C	Output voltage variation with temperature (500uV / °C).	1
OUTPUT RIPPLE + NOISE	50mVpp	20MHz bandwidth. Ripple + noise can be reduced by implementing external capacitors. See application information for details.	2
LINE REGULATION	<0.5%	Output deviation for +/- 20% step change in input voltage.	1
TRANSIENT RESPONSE	< 100uSec for output to recover within 33mV of static output following a step change in load current from full load to half load or half load to full load	50% step change in output load. 10uSec rise/fall time. Full load to half load or half load to full load.	1
MINIMUM LOAD	0W	No minimum load required for proper output regulation.	2
HOLD-UP TIME	10mSec minimum	No external hold-up capacitor attached. Requires external 250V rated capacitors to extend hold-up time.	2
HOLD-UP TIME	50mSec minimum	Full 50W output load, external 220uF hold-up capacitor attached.	2

PFC50W-SYNC-3.3V

(115Vac, 47- 800Hz Input)

50W, 3.3V/15A Single Output,

Airborne PFC Power Module



OUTPUT CHARACTERISTICS—CONTINUED

PARAMETER	PFC50W-SYNC-3.3V	REMARKS	NOTES
MAXIMUM EXTERNAL HOLD-UP CAPACITANCE	1500uF	Specified in order to not overstress the internal inrush current limiting circuit.	1
ISOLATION VOLTAGE INPUT TO CHASSIS	1500Vac, 60Hz	No arcing or damage for 60-second test duration (3.0mArms max leakage).	2
ISOLATION VOLTAGE INPUT TO OUTPUT	1500Vac, 60Hz	No arcing or damage for 60-second test duration (3.0mArms max leakage).	2
ISOLATION VOLTAGE OUTPUT TO CHASSIS	250Vdc	No arcing or damage for 60-second test duration (100Mohm min).	1
DCPWRFAIL-L (DP)	Transitions to TTL low (0.5Vmax) when 3.3Vdc output is detected outside of proper regulation window	TTL level, 3mA max sink current. Time to activation on a fault is 1mSec typical, 2.5mSec maximum.	2
ACPWRFAIL-L (AP)	Transitions to TTL low (0.5Vmax) upon detection of loss of input AC	TTL level, 3mA max sink current, 15mSec maximum delay time to activate on loss of input AC.	2
PFC 200Vdc OUTPUT	200Vrms \pm 3%	10W \leq Pout < 50W.	2, 3
MINIMUM DC/DC CONVERTER OPERATING VOLTAGE	110Vdc	Minimum amplitude for PFC output that will guarantee proper output regulation for the 3.3V output.	2
OUTPUT OVERVOLTAGE PROTECTION (3.3V OUTPUT)	3.9V \pm 3%	Pulse by pulse protection (inner loop), auto-recovery. Activation time <100uSec for overvoltage detection at a level >12% above static operating level.	1
OUTPUT OVERVOLTAGE PROTECTION (PFC 200Vdc OUTPUT)	246V \pm 3%	PFC output is clamped to this level if control loop regulation is lost. Auto-recovery when fault condition clears.	1
OUTPUT VOLTAGE ADJUSTMENT	None		--

Notes:

1. Ensured by design, not 100% tested in production.
2. 100% tested for specification compliance in production.
3. 200Vdc PFC output voltage tolerance is +/-5% for Pout < 10W.

PFC50W-SYNC-3.3V

(115Vac, 47- 800Hz Input)

50W, 3.3V/15A Single Output,

Airborne PFC Power Module



EFFICIENCY CURVE

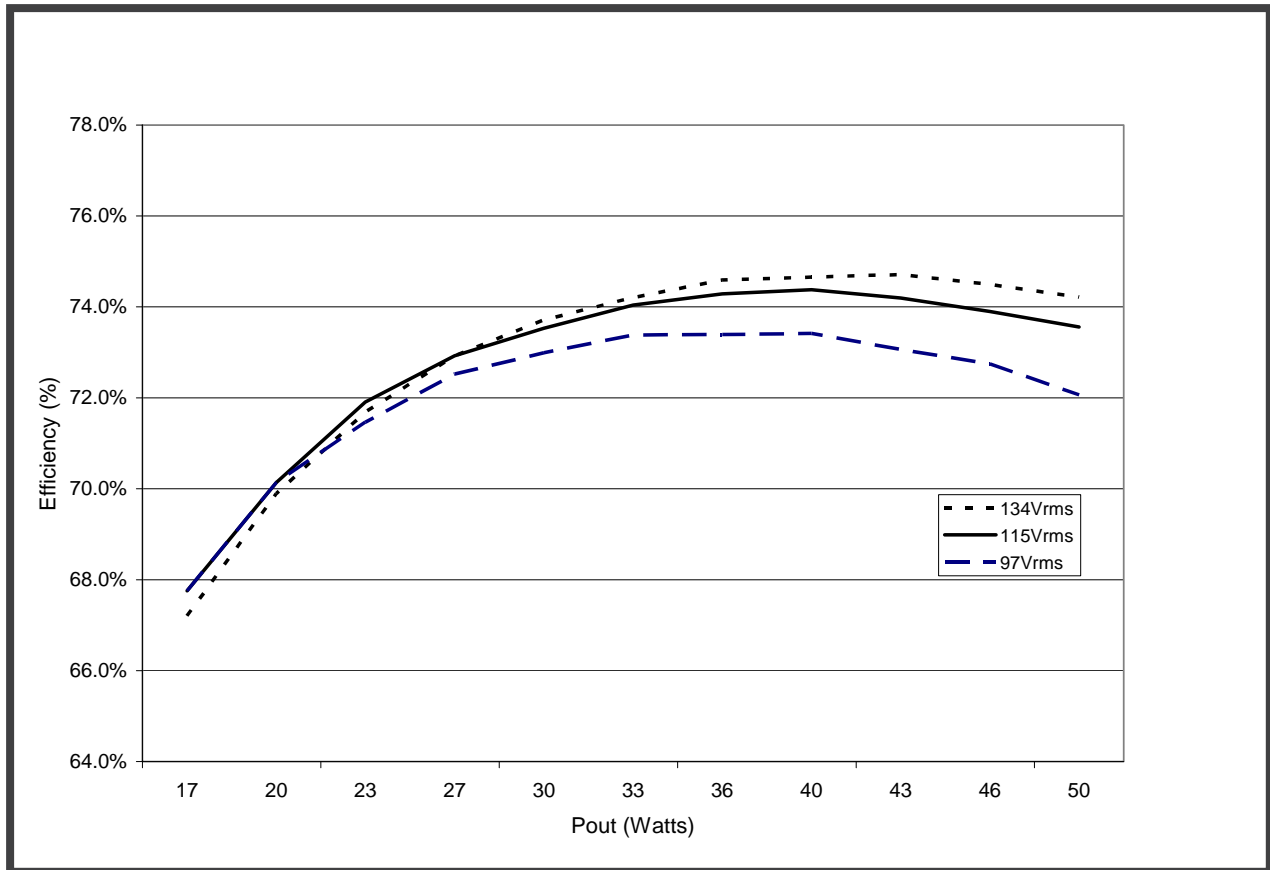

PFC50W-SYNC-3.3V

(115Vac, 47- 800Hz Input)

50W, 3.3V/15A Single Output,

Airborne PFC Power Module



APPLICATIONS INFORMATION

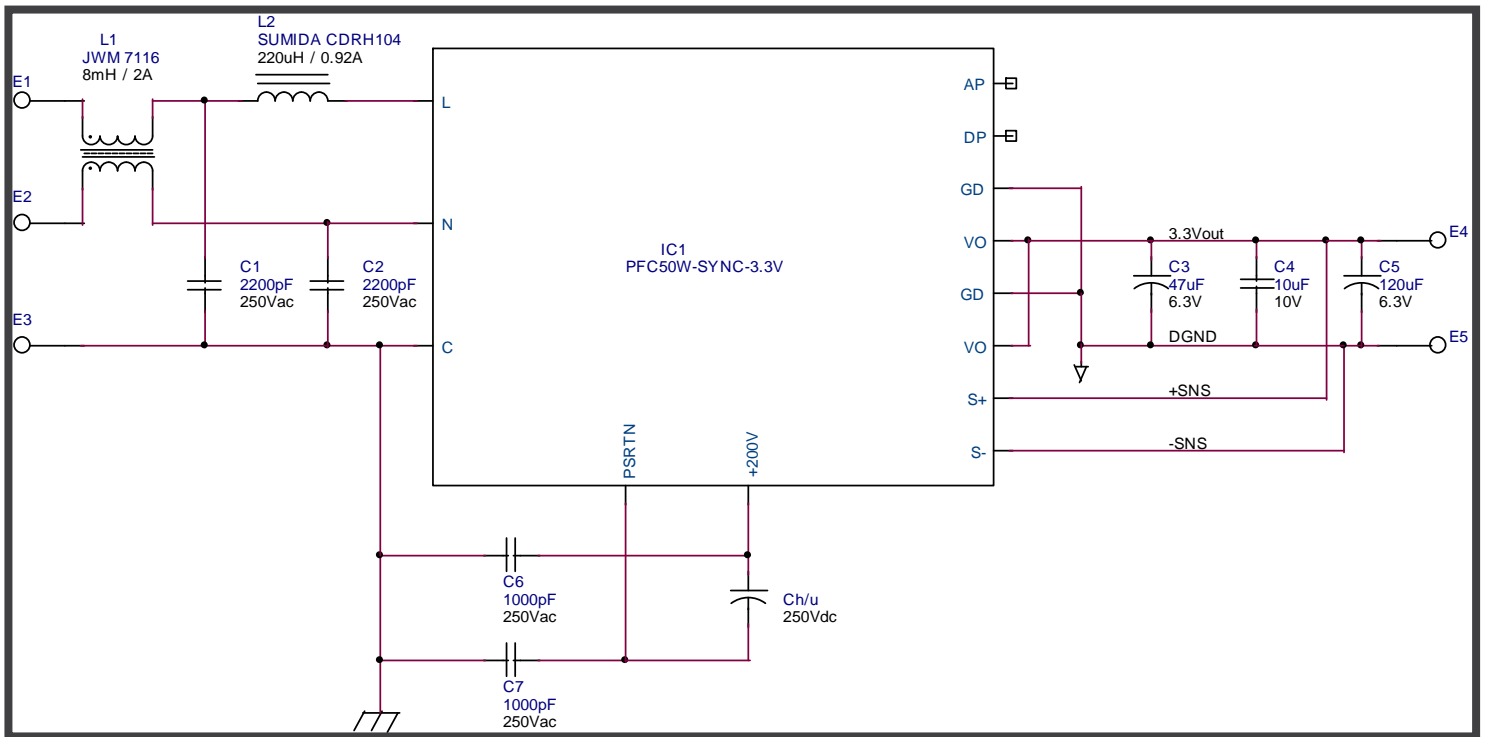

Typical Application Circuit

PFC50W-SYNC-3.3V

(115Vac, 47- 800Hz Input)

50W, 3.3V/15A Single Output,

Airborne PFC Power Module



HOLD-UP TIME

The PFC50W series module provides two interconnecting pins in order to extend hold-up time with external capacitors. In order to extend module hold-up time, polarized 250V (minimum) electrolytic capacitors must be connected externally between the module's +200Vpin and PSRTN pin. The module's internal DC/DC converter operates over the range of 210Vdc to 110Vdc; provided the "+200Vdc" amplitude is within this range, the 3.3V output will remain within proper regulation. 200Vdc is the nominal value when input AC is present. During momentary power interrupts, the required external capacitance can be determined using the following formula:

$$E = P * (t + t_{\text{restart}}) = (0.8) * \{ \frac{1}{2} C_{h/u \text{ (total)}} (V_i^2 - V_f^2) \}$$

Where,

P = output power (Watts)

t = desired hold-up time (Seconds)

t_{restart} = warm start delay of approximately 20mSec upon reapplication of input AC

C_{h/u (total)} = total hold-up capacitance (Farads), includes internal 35uF (minimum) and external capacitance

C_{h/u (ext)} = external hold-up capacitance (Farads)

0.8 factor constitutes internal DC/DC converter efficiency

V_i = Minimum PFC voltage of 194Vdc (200Vdc - 3%)

V_f = 110 Volts

In order to hold up 50W external power for 200mSec requires:

$$C_{h/u \text{ (total)}} = \{ (50W) (200mSec + 20mSec) \} \div \{ (1/2) (0.8) (194V^2 - 110V^2) \} = 1,080uF$$

$$C_{h/u \text{ (ext)}} = C_{h/u \text{ (total)}} - 35uF = 1080uF - 35uF = 1,042uF \text{ (minimum)}$$

Use of 105°C, 250Vdc, 20% tolerance snap-mount aluminum electrolytic capacitors is recommended. For the example above, a total nominal capacitance of 1,300uF would be necessary to assure the required capacitance of 1,042uF was achieved. Warm start delay occurs for AC power interrupts greater than 25mSec as a result of combination of time to reactivate PFC control circuitry, reinitiation of PFC soft-start cycle and reaching module power limit.

PLACEMENT, FLATNESS AND MOUNTING

The PFC50W series modules may be flush mounted and soldered to a PCB. The baseplate (topside) may be mounted to a flat surface for heatsinking or to a stand-alone heatsink. If mounting the baseplate to a flat surface a thermal interface pad is recommended as some warpage of the module's aluminum baseplate may exist. Warpage of the baseplate surface (including bow and twist) occurs in the manufacturing of the internal thermal clad circuit board and is a result of high temperatures required during the lamination process as well as during the panel cutting process. Baseplate warpage is limited to 0.04" per 5" unit length. Temperature activated thermally conductive interface pads, such as Chomer's T725 series, are suitable interface pads for this application.

The PFC50W module contains 4 corner threaded #4 mounting holes (see mechanical diagram for details). The standard mounting hole configuration is partially threaded; threaded approximately 0.44" through from the baseplate side of the module.

PFC50W-SYNC-3.3V

(115Vac, 47- 800Hz Input)

50W, 3.3V/15A Single Output,

Airborne PFC Power Module



SOLDERING INFORMATION

In order to minimize mechanical force exerted on the module pins, the module should be mechanically fastened to the printed circuit board prior to soldering each of the I/O pins. The pins are soldered internally to the module's horizontal through-hole circuit board using a high temperature solder that allows for application of high heat for long time durations when soldering the module to an external circuit board without concern for re-flow of the internal solder joints. The allowable heat application versus time duration curve is shown below and should be adhered to in order to prevent re-flow of the module pins internal solder joints.

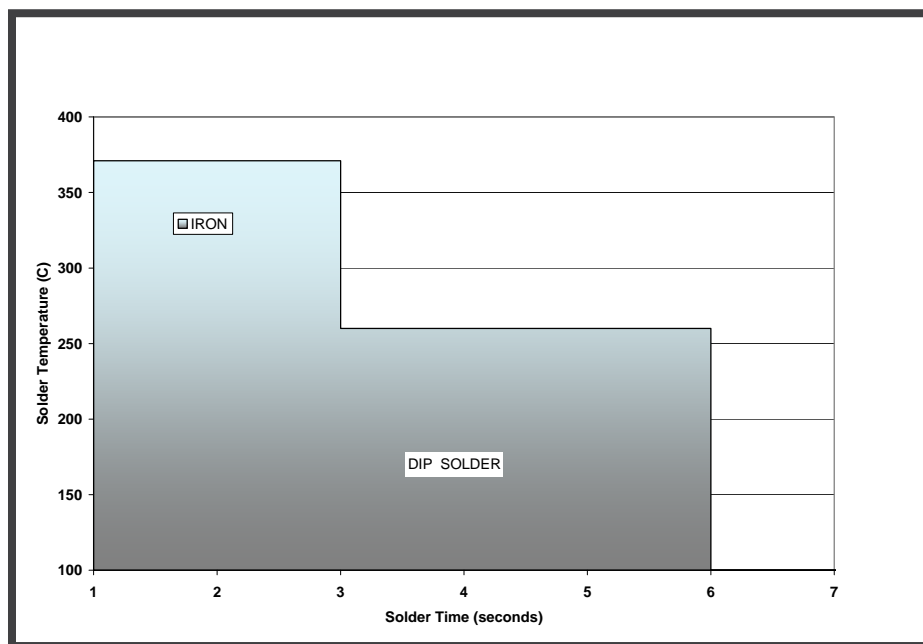

ROUTING CONSIDERATIONS

Assure there is at least 4.2mm between primary referenced and secondary referenced signals. Secondary referenced signals include AP, DP, VO, GD, S+ and S-. Avoid routing secondary referenced signals directly beneath module on component layer.

REMOTE SENSE LINES

Remote sense capability is provided in order to “margin-up” the 3.3V output to overcome small system level voltage drops in traces and connectors. If using the remote sense lines, the maximum allowable system level voltage drop (or combined differential voltage between Vout and +SNS and DGND and -SNS) is 300mV. Exceeding this amplitude may force the module's overvoltage protection circuit to activate. If not using the remote sense line feature at a remote point-of-load, each sense line should be terminated at the output pins of the module (+SNS to Vout and -SNS to DGND). Remote sense lines should be connected directly to the +3.3V and DGND power forms prior to any additional inductive filter elements that may be included.

PFC50W-SYNC-3.3V

(115Vac, 47- 800Hz Input)

50W, 3.3V/15A Single Output,

Airborne PFC Power Module



EMI CONSIDERATIONS

Use of a chassis ground plane beneath module on first internal circuit board layer (beneath component layer) of PCB is recommended. Assure that sufficient isolation distance exists between chassis plane and each of the modules input and output pins such that there is at least 4.2mm between primary referenced and secondary referenced signals. Although the PFC50W series modules contain internal common-mode and differential mode input filtering the use of a small external power line filter is recommended for EMI compliance. See typical application circuit for recommended components and values. Avoid adding line-to-line capacitance at low power levels (<20W output) as they may have an adverse effect on input current harmonic distortion at higher line frequencies (e.g., 800Hz). See application circuit for suggested filter arrangement.

If external hold-up capacitors are more than 3 inches away from module, 1000pF decoupling capacitors (line-to-earth rated) should be installed between +200V signal and chassis ground and PSRTN signal and chassis ground in close proximity to respective module terminals.

In order to reduce differential switching noise on the DC output voltage, adding a parallel combination of low ESR electrolytic and MLCC ceramic capacitors from VO to GD is recommended. Recommended low ESR electrolytic capacitors include Panasonic CD or S series (SP Cap) for the 3.3V output; MLCC capacitors include Panasonic ECJ series.

THERMAL CONSIDERATIONS

There is no derating required for module output power up to the module baseplate temperature of 100°C. Beyond this temperature the module will shutdown. In order to assure the baseplate temperature remains below 100°C additional heatsinking or forced airflow may be required. In order to estimate baseplate temperature and whether external heatsinking or airflow is necessary, apply the following formulas:

$$T_{\text{baseplate}} = T_{\text{ambient}} + (P_{\text{diss}})(\Theta_{\text{s-a}})$$

Where:

$T_{\text{baseplate}}$ = module baseplate temperature in °C,

T_{ambient} = ambient air temperature in °C,

$\Theta_{\text{s-a}}$ = thermal resistance from module baseplate to ambient air in °C/W without external heatsink,

eff = worst case module efficiency from appropriate curve,

$P_{\text{diss}} = \{(P_{\text{out}} \div \text{eff}) - P_{\text{out}}\}$ in watts

As an example,

Assume a desired output power of 50W at low line operation (97Vrms) with a maximum ambient temperature of 70°C. The following formula would apply:

$$T_{\text{baseplate}} = 70^{\circ}\text{C} + \{(50\text{W} / 0.72) - 50\text{W}\} (3.4^{\circ}\text{C/W}) = 136^{\circ}\text{C}$$

Therefore either an external heatsink would be required or forced airflow such that $\Theta_{\text{s-a}}$ was reduced to:

$$\Theta_{\text{s-a}} < \{(T_{\text{baseplate}} - T_{\text{ambient}}) \div P_{\text{diss}}\}$$

$$\Theta_{\text{s-a}} < \{100^{\circ}\text{C} - 70^{\circ}\text{C}\} \div \{(50\text{W} / 0.72) - 50\text{W}\} < 1.54^{\circ}\text{C/W}$$