

# PFC80W-12V-PBF

(115Vac, 47- 800Hz Input)

80W, 12V/6.7A Single Output,

Airborne PFC Power Module



Targeting low power avionics' applications, the **PFC80W-12V-PBF** module provides an isolated 12Vdc output with an integral PFC input converter stage. It meets the most stringent airborne requirements including those for variable frequency 115Vac generator systems over the wide frequency range of 360-800Hz and RTCA/DO-160F category M emissions.

Utilizing thermal-clad circuit board technology and low profile planar magnetics, thermal gradients between heat dissipating components and the module baseplate are minimized while maintaining a low 0.75" profile. Accurate output regulation is assured by implementation of the module's remote sense feature. Standard protection features are built-in in to assure years of fault-tolerant and reliable operation in the harshest environments.

The **PFC80W-12V-PBF** is capable of providing uninterrupted ride-through at full output load during momentary input AC brown-out conditions for up to 5mSec. Hold-up time is readily expanded by connecting external electrolytic capacitors to the PFC output pins provided.

Weighing less than 18 ounces, the **PFC80W-12V-PBF** is housed in a silicon-based encapsulated enclosure with outer dimensions of 5.0" x 3.0" x 0.75". Four corner mounting holes are included to facilitate system mounting. The **PFC80W-12V-PBF** is intended for low-profile PCB mount applications where the topside baseplate can be flush mounted to LRU chassis sidewalls or a stand-alone heatsink.



## FEATURES

	Meets both RTCA/DO-160F, section 16, and Airbus ABD0100.1.8 issue D for power factor and input current harmonic distortion levels over the wide frequency operating range (360Hz – 800Hz) at ½ to full rated load
	Wide input range: 96Vrms – 134Vrms, 47 – 800Hz
	Complies with RTCA/DO-160F for conducted emissions, susceptibility and power input (section 16)
	Active inrush current limiting: 5Apk typical, 7Apk maximum
	Size: 5.0" x 3.0" x 0.75", Weight: less than 18 ounces
	Tightly regulated isolated output: 12V / 6.7A
	Overcurrent protection with foldback current limiting
	Output overvoltage protection
	PFC output overvoltage protection with automatic restart (internal 200Vdc PFC output)
	Over-temperature shutdown with automatic restart (baseplate at or above 100°C)
	DC output valid status line (TTL)
	AC valid status line (TTL)
	MTBF: 671,140 Hours (RAIC 217Plus, Aic, 50°C operating temperature, 65% DC, 2190 Cycles/ yr.)

# PFC80W-12V-PBF

(115Vac, 47- 800Hz Input)

80W, 12V/6.7A Single Output,

Airborne PFC Power Module



## PERFORMANCE SUMMARY

PARAMETER	SPECIFICATIONS
Voltage regulation	+12.2Vdc +/-2%
Rated output current	6.7A
Pk-Pk Ripple + Noise (20MHz)	180mVpp maximum
Module Efficiency	76% typical
Output overcurrent threshold (1)	7.6A typical
Output overvoltage set-point (2)	13.6V +/- 3%
PFC output overvoltage set-point (2)	246V +/- 3%
Isolation Voltage (3) (Input to Output & Input to Chassis)	1500Vac minimum
Output ride-through / full load (4)	5mSec
Minimum load (5)	n/a

Notes:

1. 7.6A typical (8.5A maximum) with foldback current limiting and auto recovery into full load
2. Auto recovery
3. 1500Vac, 60Hz for 60 seconds without arc or damage; 3.0mArms maximum leakage current (line-to-earth capacitors installed)
4. 44uF internal hold-up capacitance, expandable by external capacitors. See application section for details.
5. No minimum load is required.

## TEMPERATURE CHARACTERISTICS

*AIRFLOW (LFM)	THERMAL IMPEDANCE ( $\theta_{s-a}$ ) (no external heatsink)
0 LFM	3.4 °C/W
250 LFM	1.0 °C/W
500 LFM	0.6 °C/W

\* Air velocity measured using a digital anemometer positioned within an airflow duct 3" X 3" above top of module



# PFC80W-12V-PBF

(115Vac, 47- 800Hz Input)

80W, 12V/6.7A Single Output,  
Airborne PFC Power Module



## BLOCK DIAGRAM

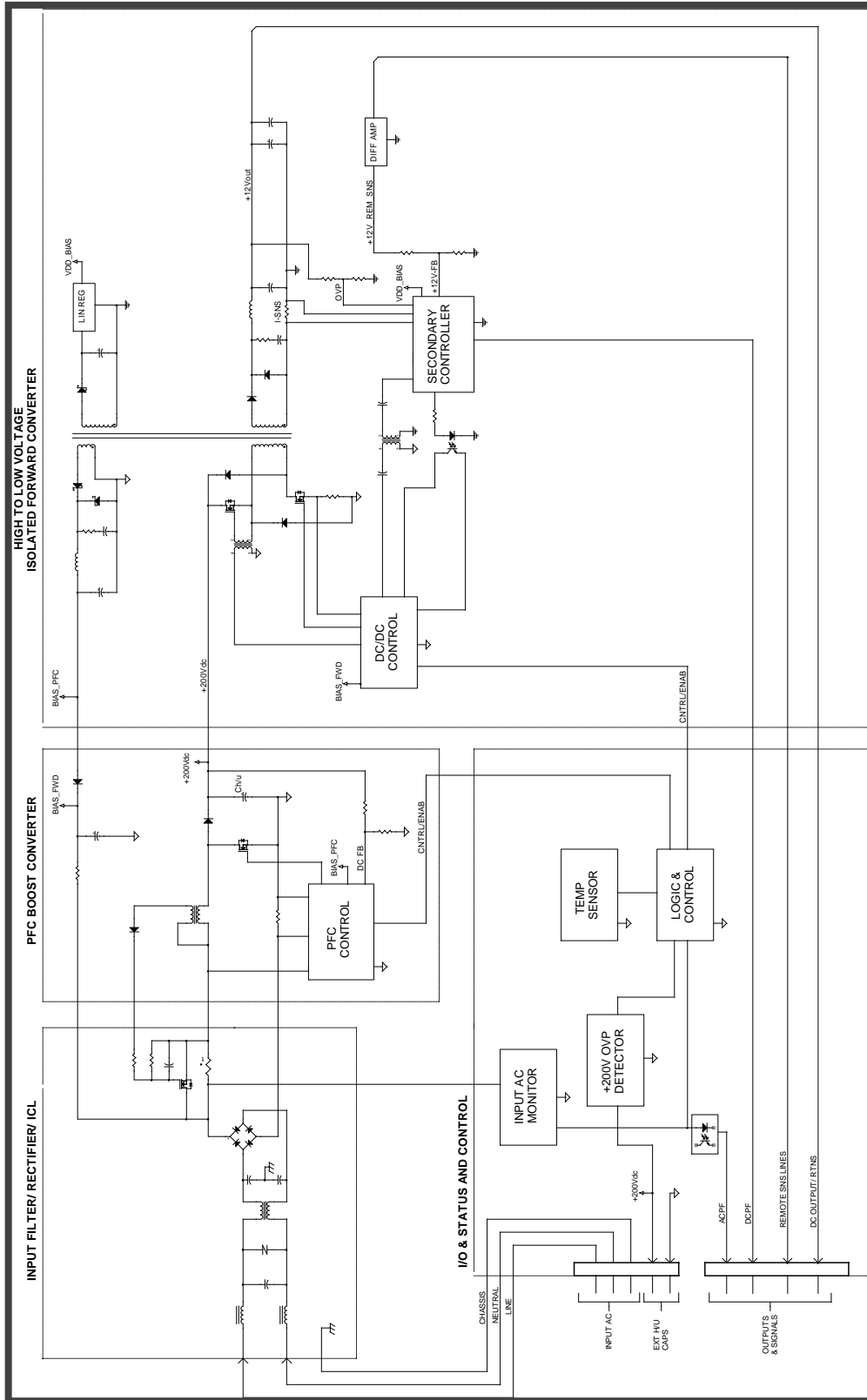

# PFC80W-12V-PBF

(115Vac, 47- 800Hz Input)

80W, 12V/6.7A Single Output,

Airborne PFC Power Module



## MECHANICAL DIAGRAM

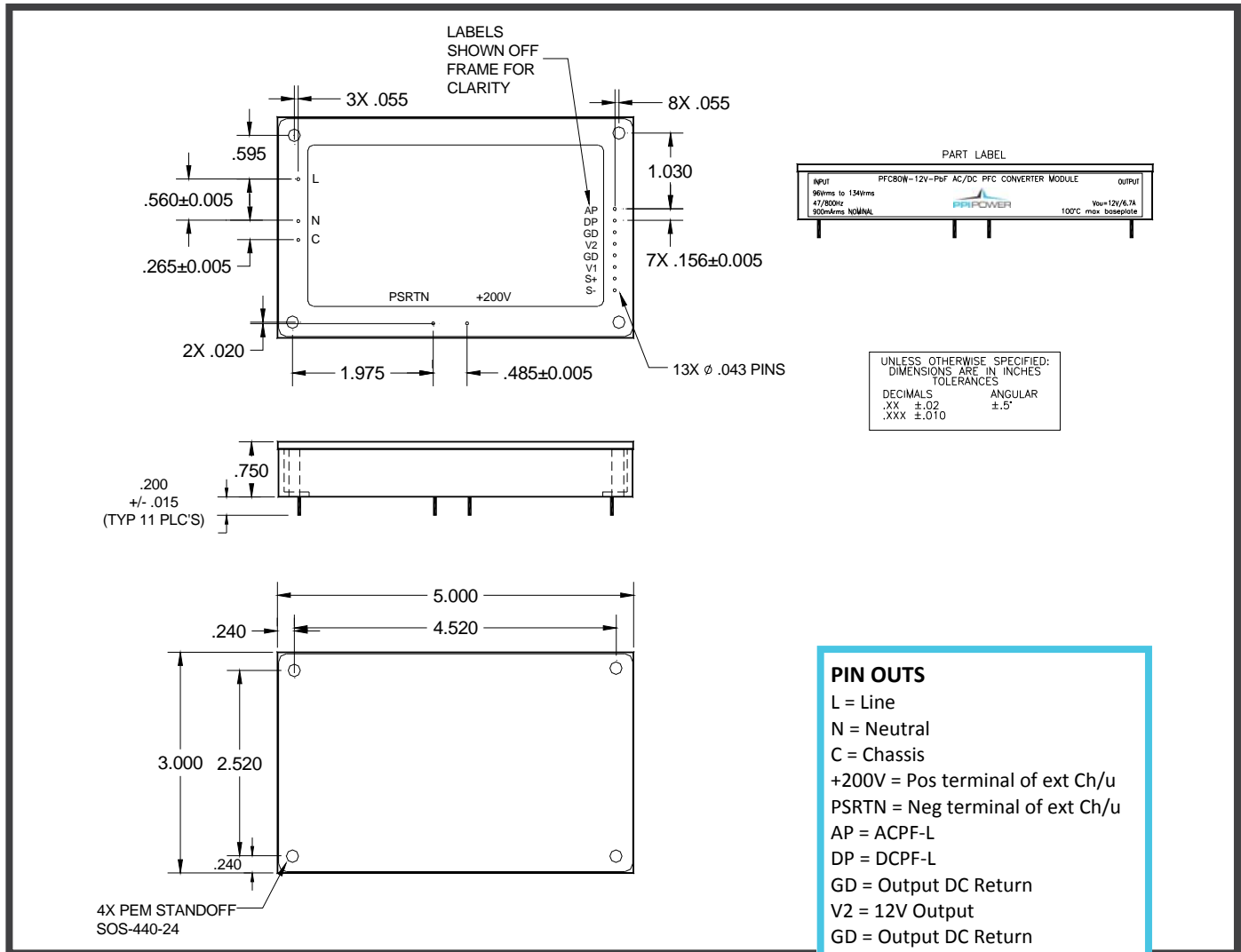

- PIN OUTS**
- L = Line
  - N = Neutral
  - C = Chassis
  - +200V = Pos terminal of ext Ch/u
  - PSRTN = Neg terminal of ext Ch/u
  - AP = ACPF-L
  - DP = DCPF-L
  - GD = Output DC Return
  - V2 = 12V Output
  - GD = Output DC Return
  - V1 = 12V Output
  - S+ = Remote sense (+)
  - S- = Remote sense (-)

**\* BASEPLATE FLATNESS**

Maximum warpage not to exceed  
0.04" per 5" unit length.

A DETAILED OUTLINE DRAWING CAN BE FURNISHED UPON REQUEST



# PFC80W-12V-PBF

(115Vac, 47- 800Hz Input)

80W, 12V/6.7A Single Output,

Airborne PFC Power Module



## ELECTRICAL SPECIFICATIONS

Unless otherwise specified the following test conditions apply:  $T_a = 25^{\circ}\text{C}$ , constant active load applied to the 12V output,  $C_h/u$  (external) = 220uF,  $V_{in} = 115\text{Vrms}$ , 360Hz – 800Hz, <1.25% sinusoid.

## INPUT CHARACTERISTICS

PARAMETER	PFC80W-12V-PBF	REMARKS	NOTES
INPUT VOLTAGE RANGE	96 – 134Vrms	Complies with normal / abnormal input voltages per DO-160F, sect. 16.	2
MUST START VOLTAGE	96Vrms minimum	Module will start and remained enabled for input voltage in the range of 96Vrms < $V_{in}$ < 134Vrms.	2
MUST INHIBIT VOLTAGE	89Vrms maximum	Module output will inhibit following ~800mSec turn-off delay upon detection of input undervoltage $\leq 89\text{Vrms}$ . 12V output to disable monotonically and remain disabled as long as input voltage remains $\leq 89\text{Vrms}$ .	2
INPUT FREQUENCY RANGE	47 – 800Hz	Reduced distortion performance below 360Hz.	2
EFFICIENCY	74% minimum	50% - 100% output load (40W - 80W). 76% typical full load efficiency.	2
LEAKAGE CURRENT	< 2mA <sub>rms</sub>	AC Line / Neutral to Chassis at 115Vrms / 400Hz.	1
INRUSH CURRENT	< 7A <sub>pk</sub>	Cold or warm start; 4A <sub>pk</sub> typical.	2
A <sub>thd</sub> INPUT CURRENT	< 5.0%	50% - 100% output load (40W - 80W).	2
INDIVIDUAL HARMONICS AC CLEAN	EVEN: <1% $I_f / n$ ( $n < 10$ ) EVEN: <0.1% $I_f$ ( $n \geq 10$ ) ODD: <30% $I_f / n$ ODD TRIPLENS:<15% $I_f / n$	$I_f$ = Fundamental current $V_{thd} < 1.25\%$ $n$ = order of harmonic (1 - 40) 50% - 100% output load (40W - 80W). Harmonics < 10mA disregarded.	1
INDIVIDUAL HARMONICS DISTORTED INPUT	EVEN: <1% $I_f / n + 1.25V_n$ ( $n < 10$ ) EVEN: <0.1% $I_f + 1.25V_n$ ( $n \geq 10$ ) ODD: <30% $I_f / n + 1.25V_n$ ODD TRIPLENS:<15% $I_f / n + 1.25V_n$	$I_f$ = Fundamental current $V_{thd} > 10\%$ (clipped method), $n$ = order of harmonic (1 - 40) $V_n$ = corr input voltage harmonic. 50% - 100% output load (40W - 80W). Harmonics < 10mA disregarded.	1

# PFC80W-12V-PBF

(115Vac, 47- 800Hz Input)

80W, 12V/6.7A Single Output,

Airborne PFC Power Module



## INPUT CHARACTERISTICS—CONTINUED

PARAMETER	PFC80W-12V-PBF	REMARKS	NOTES
QUIESCENT POWER	5W typical	No load applied to output.	1
POWER FACTOR	0.98 min	Pout > 40W at 400Hz, Pout > 55W at 800Hz.	2
CREST FACTOR (CURRENT)	1.314 – 1.514	Ratio of peak / RMS.	1
START-UP TIME	< 750mSec	Output within proper regulation.	2
CONDUCTED EMISSIONS	RTCA/DO-160F	Section 21, category M.	1, 4
STORAGE TEMPERATURE RANGE	-55°C to +100°C	Non-operational.	1
OPERATING TEMPERATURE RANGE	-15°C to +70°C	Observe maximum baseplate temperature of +100°C.	1
LOW TEMPERATURE INHIBIT	-22°C ± 3°C	Module's 12V output is inhibited at or below -22°C. Auto restart occurs when temperature rises above -22°C.	1
OVERTEMPERATURE SHUTDOWN	100°C ± 4°C	Module's 12V output is inhibited at or above 100°C. Auto restart occurs at ~ 80°C baseplate temperature.	1

# PFC80W-12V-PBF

(115Vac, 47- 800Hz Input)

80W, 12V/6.7A Single Output,

Airborne PFC Power Module



## OUTPUT CHARACTERISTICS

PARAMETER	PFC80W-12V-PBF	REMARKS	NOTES
RATED OUTPUT POWER	80W	Continuous. Observe maximum allowable baseplate temperature; see application information for details.	2
OUTPUT VOLTAGE	12.2Vdc +/-2%	Minimum load to full load (80W).	2
OUTPUT OVERCURRENT THRESHOLD	7.6A typical, 8.5A maximum	Output voltage will foldback, auto-recovery. No damage will occur to module during indefinite output short circuit conditions.	2
TEMPERATURE STABILITY COEFFICIENT	0.05% / °C	Output voltage variation with temperature (500uV / °C).	1
OUTPUT RIPPLE + NOISE	180mVpp maximum	20MHz bandwidth. 100mVpp typical. Can be reduced with external capacitors, see application notes.	2
LINE REGULATION	<0.5%	Output deviation for +/- 20% step change in input voltage.	1
LOAD REGULATION	Output remains in regulation	50% step change in output load. Full load to half load or half load to full load. 10uSec rise/fall time.	1
MINIMUM LOAD	0A	No minimum load is necessary.	2
HOLD-UP TIME	5mSec nominal	No external hold-up capacitor attached. Requires external 250V rated capacitors to extend hold-up time. May be affected by warm start delay, see application section for details.	1
MAXIMUM EXTERNAL HOLD-UP CAPACITANCE	2800uF	Specified in order to not overstress the internal inrush current limiting circuit	1
ISOLATION VOLTAGE INPUT TO CHASSIS	1500Vac, 60Hz	No arcing or damage for 60-second test duration (3.0mArms max leakage).	2, 5
ISOLATION VOLTAGE INPUT TO OUTPUT	1500Vac, 60Hz	No arcing or damage for 60-second test duration (3.0mArms max leakage).	2, 6
ISOLATION VOLTAGE OUTPUT TO CHASSIS	250Vdc	No arcing or damage for 60-second test duration (100Mohm min).	1
DCPWRFAIL-L (DP)	Transitions to TTL low (0.5Vmax) when 12Vdc output is detected outside of proper regulation window	TTL level, 3mA max sink current. Time to activation on a fault is 1mSec typical, 2.5mSec maximum.	2

# PFC80W-12V-PBF

(115Vac, 47- 800Hz Input)

80W, 12V/6.7A Single Output,

Airborne PFC Power Module



## OUTPUT CHARACTERISTICS—CONTINUED

PARAMETER	PFC80W-12V-PBF	REMARKS	NOTES
ACPWRFAIL-L (AP)	Transitions to TTL low (0.5Vmax) upon detection of invalid input AC ( $\leq 89V_{rms}$ from 0% - 100% load)	TTL level, 16mA max sink current, 5mSec maximum delay time to activate on loss of input AC.	2
PFC 200Vdc OUTPUT	200Vdc $\pm$ 3%	10W $\leq$ Pout < 80W.	2, 3
MINIMUM DC/DC CONVERTER OPERATING VOLTAGE	95Vdc	Minimum amplitude for PFC output that will guarantee proper output regulation for the 12V output.	1
OUTPUT OVERVOLTAGE PROTECTION	13.6V $\pm$ 3%	Pulse by pulse protection (inner loop), auto-restart.	1
OUTPUT OVERVOLTAGE PROTECTION (PFC 200Vdc OUTPUT)	246V $\pm$ 3%	PFC output is clamped to this level if control loop regulation is lost, auto-recovery.	1
OUTPUT VOLTAGE ADJUSTMENT	None		--

### Notes:

1. Ensured by design, not 100% tested in production.
2. 100% tested for specification compliance in production.
3. 200Vdc PFC output voltage tolerance is +/-5% for Pout < 10W.
4. May require small external inductor, common-mode inductor or X capacitor installed on power lines for full compliance when installed in upper level assembly, see application section for details.
5. When performing input to chassis isolation voltage testing at the module level it is recommended to tie the primary referenced terminals: Line, Neutral, +200V and PSRTN together and hi-pot all of these with respect to chassis ground.
6. When performing input to output isolation voltage testing at the module level it is recommended to tie the primary referenced terminals: Line, Neutral, +200V and PSRTN together and hi-pot all of these with respect to all of the secondary referenced terminals which are also tied together (this includes AP, DP, GD, VO, S+ and S-).



# PFC80W-12V-PBF

(115Vac, 47- 800Hz Input)

80W, 12V/6.7A Single Output,

Airborne PFC Power Module



## EFFICIENCY CURVE

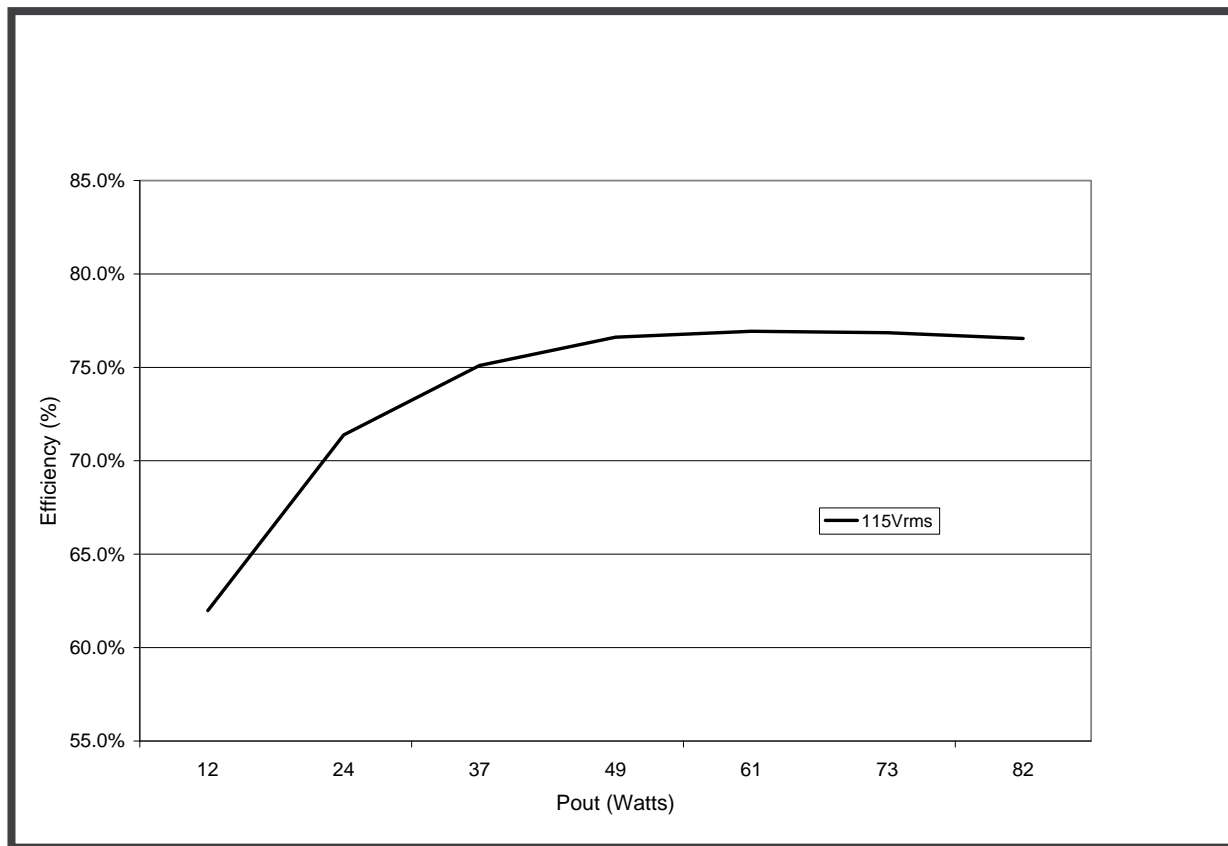

# PFC80W-12V-PBF

(115Vac, 47- 800Hz Input)

80W, 12V/6.7A Single Output,  
Airborne PFC Power Module



## APPLICATIONS' INFORMATION

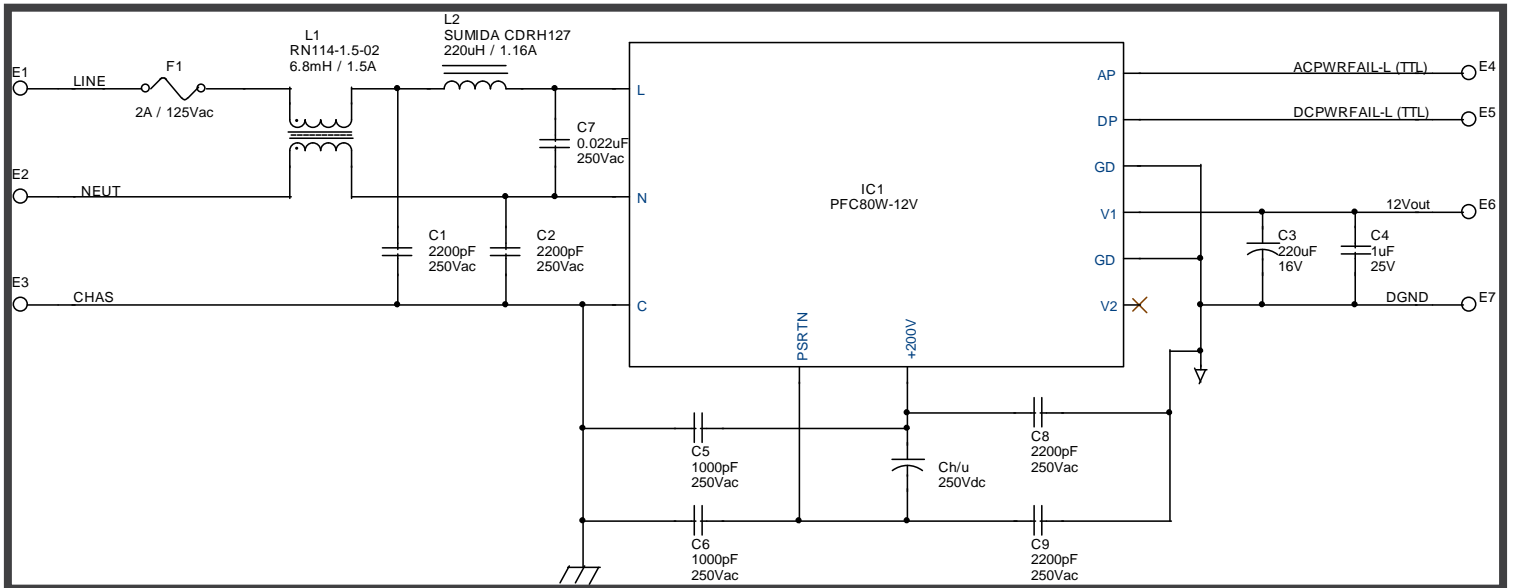

Typical Application Circuit

# PFC80W-12V-PBF

(115Vac, 47- 800Hz Input)

80W, 12V/6.7A Single Output,

Airborne PFC Power Module



## HOLD-UP TIME

The PFC80W series module provides two interconnecting pins in order to extend hold-up time with external capacitors. In order to extend module hold-up time, polarized 250V (minimum) electrolytic capacitors must be connected externally between the module's +200Vpin and PSRTN pin. Required external capacitance can be determined using the following formula:

$$E = P * (t + t_{\text{restart}}) = (0.85) * \{ \frac{1}{2} C_{h/u} (\text{total}) (V_i^2 - V_f^2) \}$$

Where,

P = output power (Watts)

t = desired hold-up time (Seconds)

t<sub>restart</sub> = warm start delay of approximately 20mSec upon reapplication of input AC

C<sub>h/u</sub> (total) = total hold-up capacitance (Farads), includes internal 35uF (minimum) and external capacitance

C<sub>h/u</sub> (ext) = external hold-up capacitance (Farads)

0.85 factor constitutes internal DC/DC converter efficiency

V<sub>i</sub> = Minimum PFC voltage of 194Vdc (200Vdc - 3%)

V<sub>f</sub> = 95 Volts

$$E = P * (t + t_{\text{restart}}) = (0.85) * \{ \frac{1}{2} C_{h/u} (V_i^2 - V_f^2) \}$$

In order to hold up 80W external power for 200mSec requires:

$$C_{h/u} (\text{total}) = \{ (80W) (200\text{mSec} + 20\text{mSec}) \} \div \{ (1/2) (0.85) (194V^2 - 95V^2) \} = 1450\mu\text{F}$$

$$C_{h/u} (\text{ext}) = C_{h/u} (\text{total}) - 35\mu\text{F} = 1450\mu\text{F} - 35\mu\text{F} = 1410\mu\text{F} (\text{minimum})$$

Use of 105°C, 250Vdc, 20% tolerance snap-mount aluminum electrolytic capacitors is recommended. For the example above, a total nominal capacitance of 1770uF would be necessary to assure the required capacitance of 1410uF was achieved. Warm start delay occurs for AC power interrupts greater than 25mSec as a result of combination of time to reactivate PFC control circuitry, reinitiation of PFC soft-start cycle and reaching module power limit.

## PLACEMENT, FLATNESS AND MOUNTING

The PFC80W series modules may be flush mounted and soldered to a PCB. The baseplate (topside) may be mounted to a flat surface for heatsinking or to a stand-alone heatsink. If mounting the baseplate to a flat surface a thermal interface pad is recommended as some warpage of the module's aluminum baseplate may exist. Warpage of the baseplate surface (including bow and twist) occurs in the manufacturing of the internal thermal clad circuit board and is a result of high temperatures required during the lamination process as well as during the panel cutting process. Baseplate warpage is limited to 0.04" per 5" unit length. Temperature activated thermally conductive interface pads, such as Chomerics' T725 series, are suitable interface pads for this application.

The PFC80W module contains 4 corner threaded #4 mounting holes (see mechanical diagram for details). The standard mounting hole configuration is partially threaded; threaded approximately 0.44" through from the baseplate side of the module.

# PFC80W-12V-PBF

(115Vac, 47- 800Hz Input)

80W, 12V/6.7A Single Output,

Airborne PFC Power Module



## SOLDERING INFORMATION

In order to minimize mechanical force exerted on the module pins, the module should be mechanically fastened to the printed circuit board prior to soldering each of the I/O pins. The pins are soldered internally to the module's horizontal through-hole circuit board using a high temperature solder that allows for application of high heat for long time durations when soldering the module to an external circuit board without concern for re-flow of the internal solder joints. The allowable heat application versus time duration curve is shown below and should be adhered to in order to prevent re-flow of the module pins internal solder joints.

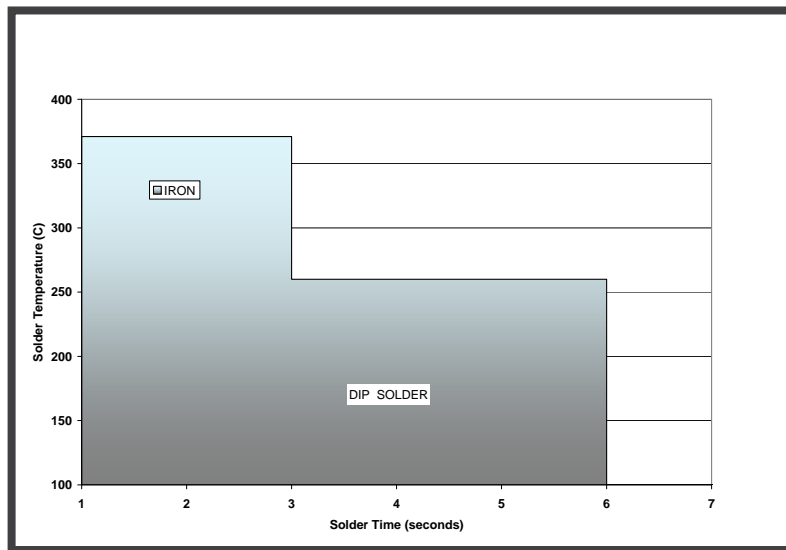

## ROUTING CONSIDERATIONS

Assure there is at least 4.2mm between primary referenced and secondary referenced signals. Secondary referenced signals include AP, DP, VO, GD, S+ and S-. Avoid routing secondary referenced signals directly beneath module on component layer.

## REMOTE SENSE LINES

Remote sense capability is provided in order to “margin-up” the 12V output to overcome small system level voltage drops in traces and connectors. If using the remote sense lines, the maximum allowable system level voltage drop (or combined differential voltage between Vout and +SNS and DGND and -SNS) is 700mV. Exceeding this amplitude may force the module's overvoltage protection circuit to activate. If not using the remote sense line feature at a remote point-of-load, each sense line should be terminated at the output pins of the module (+SNS to Vout and -SNS to DGND). Remote sense lines should be connected directly to the +12V and DGND power forms prior to any additional inductive filter elements that may be included.

## CAPACITIVE LOADING AND PROPER POWER-UP CONSIDERATIONS

Avoid applying full (6.7A) load current to the module's output prior to allowing the output to reach at least 6Vdc to avoid module latch-up when starting. Module latch-up can occur under certain power-up modes (e.g., low line) if the module enters internal power-limit prior to its internal bias voltages reaching minimum operating levels. If implementing active loading on the modules output (constant current sink), assure that the turn-on voltage of the active load instrument is set to at least 6Vdc. If implementing external bulk capacitors on the module's 12V output, assure proper power-up under all input line and output load conditions.

# PFC80W-12V-PBF

(115Vac, 47- 800Hz Input)

80W, 12V/6.7A Single Output,

Airborne PFC Power Module



## EMI CONSIDERATIONS

Use of a chassis ground plane beneath module on first internal circuit board layer (beneath component layer) of PCB is recommended. Assure that sufficient isolation distance exists between chassis plane and each of the modules input and output pins such that there is at least 4.2mm between primary referenced and secondary referenced signals. Although the PFC80W series modules contain internal common-mode and differential mode input filtering the use of a small external inductive based line filter is recommended for EMI compliance. See application circuit for suggested filter arrangement. Reduce or eliminate line-to-line capacitance (C7) for applications operating at low power levels (<40W output) as it may have an adverse effect on input current harmonic distortion at higher line frequencies (e.g., 800Hz).

If external hold-up capacitors are more than 3 inches away from module, 1000pF decoupling capacitors (line-to-earth rated) should be installed between +200V signal and chassis ground and PSRTN signal and chassis ground in close proximity to respective module terminals.

In order to reduce differential switching noise on the DC output voltage, adding a parallel combination of low ESR electrolytic and MLCC ceramic capacitors from V1 to GD is recommended. Recommended low ESR electrolytic capacitors include United Chemicon NPCAP series for the 12V output and Panasonic ECJ series for the MLCC capacitors.

## THERMAL CONSIDERATIONS

There is no derating required for module output power up to the module baseplate temperature of 100°C. Beyond this temperature the module will shutdown. In order to assure the baseplate temperature remains below 100°C additional heatsinking or forced airflow may be required. In order to estimate baseplate temperature and whether external heatsinking or airflow is necessary, apply the following formulas:

$$T_{\text{baseplate}} = T_{\text{ambient}} + (P_{\text{diss}})(\Theta_{\text{s-a}})$$

Where:

$T_{\text{baseplate}}$  = module baseplate temperature in °C,

$T_{\text{ambient}}$  = ambient air temperature in °C,

$\Theta_{\text{s-a}}$  = thermal resistance from module baseplate to ambient air in °C/W without external heatsink,

eff = worst case module efficiency from appropriate curve,

$P_{\text{diss}}$  =  $\{(P_{\text{out}} \div \text{eff}) - P_{\text{out}}\}$  in watts

As an example,

Assume a desired output power of 50W at low line operation (90Vrms) with a maximum ambient temperature of 70°C. The following formula would apply:

$$T_{\text{baseplate}} = 70^{\circ}\text{C} + \{(50\text{W} / 0.76) - 50\text{W}\} (3.4^{\circ}\text{C}/\text{W}) = 124^{\circ}\text{C}$$

Therefore either an external heatsink would be required or forced airflow such that  $\Theta_{\text{s-a}}$  was reduced to:

$$\Theta_{\text{s-a}} < \{(T_{\text{baseplate}} - T_{\text{ambient}}) \div P_{\text{diss}}\}$$

$$\Theta_{\text{s-a}} < \{100^{\circ}\text{C} - 70^{\circ}\text{C}\} \div \{(50\text{W} / 0.76) - 50\text{W}\} < 1.90^{\circ}\text{C}/\text{W}$$

